



HDA Design anchor

	Anchor version	Benefits
	HDA-P HDA-PR HDA-PF Anchor for pre-setting	<ul style="list-style-type: none"> - suitable for non-cracked and cracked concrete C 20/25 to C 50/60 - mechanical interlock (undercut) - low expansion force (thus small edge distance / spacing) - automatic undercutting (without special undercutting tool) - high loading capacity, performance of a headed stud - complete system (anchor, stop drill bit, setting tool, drill hammer) - setting mark on anchor for control (easy and safe) - completely removable - test reports: fire resistance, fatigue, shock, seismic
	HDA-T HDA-TR HDA-TF Anchor for through-fastening	



Concrete

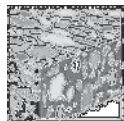

Tensile zone

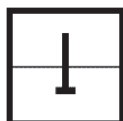

Performance of a headed stud



Small edge distance and spacing



Fire resistance



Fatigue



Shock



Seismic



Corrosion resistance



Nuclear power plant approval



European Technical Approval



CE conformity



PROFIS Anchor design software

Approvals / certificates

Description	Authority / Laboratory	No. / date of issue
European technical approval ^{a)}	CSTB, Paris	ETA-99/0009 / 2010-12-17
ICC-ES report incl. seismic	ICC evaluation service	ESR 1546 / 2012-03-01
Shockproof fastenings in civil defence installations	Federal Office for Civil Protection, Bern	BZS D 09-601/ 2009-10-21
Nuclear power plants	DIBt, Berlin	Z-21.1-1696 / 2011-02-16
Fatigue loading	DIBt, Berlin	Z-21.1-1693 / 2011-10-01
Fire test report	IBMB, Braunschweig	UB 3039/8151-CM / 2001-01-31
Assessment report (fire)	warringtonfire	WF 166402 / 2007-10-26

a) All data for HDA-P(R) and HDA-T(R) given in this section according ETA-99/0009, issue 2010-12-17. Sherardized versions HDA-PF and HDA-TF anchors are not covered by the approvals.

Basic loading data (for a single anchor)

All data in this section applies to

For details see Simplified design method

- Correct setting (See setting instruction)
- No edge distance and spacing influence
- Concrete as specified in the table
- **Steel** failure
- Minimum base material thickness
- Concrete C 20/25, $f_{ck,cube} = 25 \text{ N/mm}^2$

Mean ultimate resistance

Anchor size	Non-cracked concrete				Cracked concrete			
	M10	M12	M16	M20 ^{a)}	M10	M12	M16	M20 ^{a)}
Tensile $N_{Ru,m}$								
HDA-P(F), HDA-T(F) ^{b)} [kN]	48,7	70,9	133,3	203,2	33,3	46,7	100	126,7
HDA-PR, HDA-TR [kN]	48,7	70,9	133,3	203,2	33,3	46,7	100	126,7
Shear $V_{Ru,m}$								
HDA-P, HDA-PF ^{b)} [kN]	23,3	31,7	65,6	97,4	23,3	31,7	65,6	97,4
HDA-PR [kN]	24,3	36,0	66,7	-	24,3	36,0	66,7	-
HDA-T, HDA-TF ^{b) c)} [kN]	68,8	84,7	148,2	216,9	68,8	84,7	148,2	216,9
HDA-TR ^{c)} [kN]	75,1	92,1	160,9	-	75,1	92,1	160,9	-

a) HDA M20: only a galvanized 5 μ m version is available

b) HDA-PF and HDA-TF anchors are not covered by ETA-99/0009

c) Values are valid for minimum thickness of the base plate $t_{fix,min}$ without use of centering washer (see setting details)

Characteristic resistance

Anchor size	Non-cracked concrete				Cracked concrete			
	M10	M12	M16	M20 ^{a)}	M10	M12	M16	M20 ^{a)}
Tensile N_{Rk}								
HDA-P(F), HDA-T(F) ^{b)} [kN]	46	67	126	192	25	35	75	95
HDA-PR, HDA-TR [kN]	46	67	126	-	25	35	75	-

Anchor size	Non-cracked and cracked concrete															
	M10		M12				M16				M20 ^{a)}					
Shear V_{Rk}																
HDA-P, HDA-PF ^{b)} [kN]	22		30				62				92					
HDA-PR	23		34				63				-					
for t_{fix}	[mm]	10 \leq	15 \leq	10 \leq	15 \leq	20 \leq	15 \leq	20 \leq	25 \leq	30 \leq	35 \leq	20 \leq	25 \leq	40 \leq	55 \leq	
	[mm]	<15	\leq 20	<15	<20	\leq 50	<20	<25	<30	<35	\leq 60	<25	<40	<55	\leq 100	
HDA-T, HDA-TF ^{b)} [kN]	65 ^{c)}	65	80 ^{c)}	80	100	140 ^{c)}	140	155	170	190	205 ^{c)}	205	235	250		
for t_{fix}	[mm]	10 \leq	15 \leq	10 \leq	15 \leq	20 \leq	30 \leq	20 \leq	25 \leq	30 \leq	35 \leq	-				
	[mm]	<15	\leq 20	<15	<20	<30	\leq 50	<25	<30	<35	\leq 60	-				
HDA-TR [kN]	71 ^{c)}	71	87 ^{c)}	87	94	109	152 ^{c)}	152	158	170	-					

a) HDA M20: only a galvanized 5 μ m version is available

b) HDA-PF and HDA-TF anchors are not covered by ETA-99/0009

c) With use of centering washer ($t = 5 \text{ mm}$) only

Design resistance

Anchor size	Non-cracked concrete				Cracked concrete			
	M10	M12	M16	M20 ^{a)}	M10	M12	M16	M20 ^{a)}
Tensile N_{Rd}								
HDA-P(F), HDA-T(F) ^{b)} [kN]	30,7	44,7	84,0	128,0	16,7	23,3	50,0	63,3
HDA-PR, HDA-TR [kN]	28,8	41,9	78,8	-	16,7	23,3	50,0	-

Anchor size	Non-cracked and cracked concrete														
	M10		M12			M16				M20 ^{a)}					
Shear V_{Rd}															
HDA-P, HDA-PF ^{b)} [kN]	17,6		24,0			49,6				73,6					
HDA-PR	17,3		25,6			47,4				-					
for t_{fix}	[mm]	10≤	15≤	10≤	15≤	20≤	15≤	20≤	25≤	30≤	35≤	20≤	25≤	40≤	55≤
	[mm]	<15	≤20	<15	<20	≤50	<20	<25	<30	<35	≤60	<25	<40	<55	≤100
HDA-T, HDA-TF ^{b)} [kN]	43 ^{c)}	43	53 ^{c)}	53	67	93 ^{c)}	93	103	113	127	137 ^{c)}	137	157	167	
for t_{fix}	[mm]	10≤	15≤	10≤	15≤	20≤	30≤	20≤	25≤	30≤	35≤	-			
	[mm]	<15	≤20	<15	<20	<30	≤50	<25	<30	<35	≤60	-			
HDA-TR [kN]	53 ^{c)}	53	65 ^{c)}	65	71	82	114 ^{c)}	114	119	128	-				

a) HDA M20: only a galvanized 5 μ m version is available

b) HDA-PF and HDA-TF anchors are not covered by ETA-99/0009

c) With use of centering washer ($t = 5$ mm) only

Recommended loads

Anchor size	Non-cracked concrete				Cracked concrete			
	M10	M12	M16	M20 ^{a)}	M10	M12	M16	M20 ^{a)}
Tensile N_{Rec} ^{b)}								
HDA-P(F), HDA-T(F) ^{c)} [kN]	21,9	31,9	60,0	91,4	11,9	16,7	35,7	45,2
HDA-PR, HDA-TR [kN]	20,5	29,9	56,3	-	11,9	16,7	35,7	-

Anchor size	Non-cracked and cracked concrete														
	M10		M12			M16				M20 ^{a)}					
Shear V_{Rec} ^{b)}															
HDA-P, HDA-PF ^{c)} [kN]	12,6		17,1			35,4				52,6					
HDA-PR	12,3		18,2			33,8				-					
for t_{fix}	[mm]	10≤	15≤	10≤	15≤	20≤	15≤	20≤	25≤	30≤	35≤	20≤	25≤	40≤	55≤
	[mm]	<15	≤20	<15	<20	≤50	<20	<25	<30	<35	≤60	<25	<40	<55	≤100
HDA-T, HDA-TF ^{c)} [kN]	31 ^{d)}	31	38 ^{d)}	38	48	67 ^{d)}	67	74	81	90	98 ^{d)}	98	112	119	
for t_{fix}	[mm]	10≤	15≤	10≤	15≤	20≤	30≤	20≤	25≤	30≤	35≤	-			
	[mm]	<15	≤20	<15	<20	<30	≤50	<25	<30	<35	≤60	-			
HDA-TR [kN]	38 ^{d)}	38	47 ^{d)}	47	50	59	82 ^{d)}	82	85	91	-				

a) HDA M20: only a galvanized 5 μ m version is available

b) With overall partial safety factor for action $\gamma_F = 1,4$. The partial safety factors for action γ depend on the type of loading and shall be taken from national regulations.

c) HDA-PF and HDA-TF anchors are not covered by ETA-99/0009

d) With use of centering washer ($t = 5$ mm) only

Materials

Mechanical properties of HDA

Anchor size	HDA-P(F), HDA-T(F)				HDA-PR, HDA-TR		
	M10	M12	M16	M20 ^{a)}	M10	M12	M16
Anchor bolt							
Nominal tensile strength f_{uk} [N/mm ²]	800	800	800	800	800	800	800
Yield strength f_{yk} [N/mm ²]	640	640	640	640	600	600	600
Stressed cross-section A_s [mm ²]	58,0	84,3	157	245	58,0	84,3	157
Moment of resistance W_{el} [mm ³]	62,3	109,2	277,5	540,9	62,3	109,2	277,5
Characteristic bending resistance without sleeve $M_{Rk,s}^0$ [Nm]	60	105	266	519	60	105	266
Anchor sleeve							
Nominal tensile strength f_{uk} [N/mm ²]	850	850	700	550	850	850	700
Yield strength f_{yk} [N/mm ²]	600	600	600	450	600	600	600

a) HDA M20: only a galvanized 5µm version is available

b) The recommended bending moment of the HDA anchor bolt may be calculated from $M_{rec} = M_{Rd,s} / \gamma_F = M_{Rk,s} / (\gamma_{Ms} \cdot \gamma_F) = (1,2 \cdot W_{el} \cdot f_{uk}) / (\gamma_{Ms} \cdot \gamma_F)$, where the partial safety factor for bolts of strength 8.8 is $\gamma_{Ms} = 1,25$, for A4-80 equal to 1,33 and the partial safety factor for action may be taken as $\gamma_F = 1,4$. In case of HDA-T/TR/TF the bending capacity of the sleeve is neglected, only the capacity of the bolt is taken into account.

Material quality

Part	Material
HDA-P / HDA-T (Carbon steel version)	
Sleeve:	Machined steel with brazed tungsten carbide tips, galvanised to min. 5 µm
Bolt M10 - M16:	Cold formed steel, strength 8.8, galvanised to min. 5 µm
Bolt M20:	Cone machined, rod strength 8.8, galvanised to min. 5 µm
HDA-PR / HDA-TR (Stainless steel version)	
Sleeve:	Machined stainless steel with brazed tungsten carbide tips
Bolt M10 - M16:	Cone/rod: machined stainless steel
HDA-PF / HDA-TF (Sherardized version)	
Sleeve:	Machined steel with brazed tungsten carbide tips, shearadized
Bolt M10 - M16:	Cold formed steel, strength 8.8, shearadized

Anchor dimensions

HDA-P / HDA-PR / HDA-PF

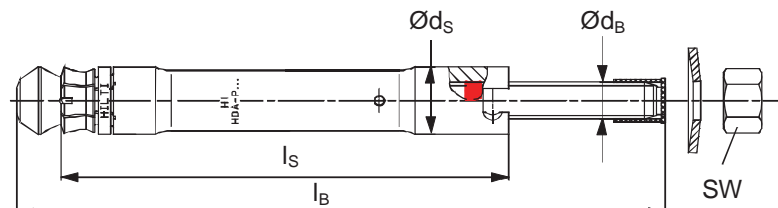

HDA-T / HDA-TR / HDA-TF

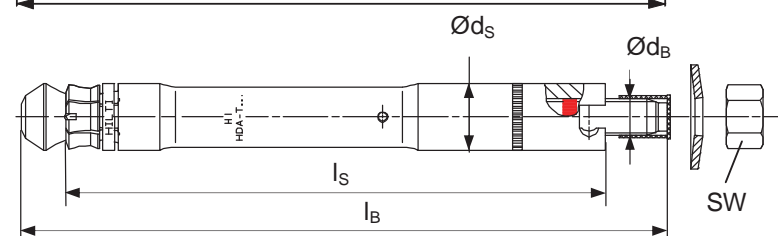

Dimensions of HDA

Anchor size	HDA-P / HDA-PR / HDA-PF / HDA-T / HDA-TR / HDA-TF						
	M10 x100/20	M12 x125/30 x125/50		M16 x190/40 x190/60		M20 x250/50 x250/100	
Length code letter	I	L	N	R	S	V	X
Total length of bolt l_B [mm]	150	190	210	275	295	360	410
Diameter of bolt d_B [mm]	10	12		16		20	
Total length of sleeve							
HDA-P l_s [mm]	100	125	125	190	190	250	250
HDA-T l_s [mm]	120	155	175	230	250	300	350
Max. diameter of sleeve d_s [mm]	19	21		29		35	
Washer diameter d_w [mm]	27,5	33,5		45,5		50	
Width across flats S_w [mm]	17	19		24		30	

Setting

Drilling



The stop drill is required for drilling in order to achieve the correct hole depth.

Anchor	Stop drill bit with TE-C (SDS plus) connection end	Stop drill bit with TE-Y (SDS max) connection end
HDA-P/ PF/ PR M10x100/20	TE-C-HDA-B 20x100	TE-Y-HDA-B 20x100
HDA-T/ TF/ TR M10x100/20	TE-C-HDA-B 20x120	TE-Y-HDA-B 20x120
HDA-P/ PF/ PR M12x125/30 HDA-P/ PF/ PR M12x125/50	TE-C HDA-B 22x125	TE-Y HDA-B 22x125
HDA-T/ TF/ TR M12x125/30 HDA-T/ TF/ TR M12x125/50	TE-C HDA-B 22x155 TE-C HDA-B 22x175	TE-Y HDA-B 22x155 TE-Y HDA-B 22x175
HDA-P/ PF/ PR M16 x190/40 HDA-P/ PF/ PR M16 x190/60		TE-Y HDA-B 30x190
HDA-T/ TF/ TR M16x190/40 HDA-T/ TF/ TR M16x190/60		TE-Y HDA-B 30x230 TE-Y HDA-B 30x250
HDA-P M20 x250/50 HDA-P M20 x250/100		TE-Y HDA-B 37x250
HDA-T M20x250/50 HDA-T M20x250/100		TE-Y HDA-B 37x300 TE-Y HDA-B 37x350

Setting

Drilling hammer



Setting tool



The setting system (tool and setting tool) is required for transferring the specific energy for the undercutting process.

Anchor											Setting tool						
	TE 24 ^{a)}	TE 25 ^{a)}	TE 35	TE 40	TE 40 AVR	TE 56	TE 56-ATC	TE 60	TE 60-ATC	TE 70		TE 70-ATC	TE 75	TE 76	TE 76-ATC	TE 80-ATC	TE 80-ATC AVR
HDA-P/T20-M10x100/20	■			■													TE-C-HDA-ST 20 M10
						■		■									TE-Y-HDA-ST 20 M10
HDA-P/T 22-M12x125/30 HDA-P/T 22-M12x125/50	■			■													TE-C-HDA-ST 22 M12
	■			■		■		■									TE-Y-HDA-ST 22 M12
HDA-P/T 30-M16x190/40 HDA-P/T 30-M16x190/60									■		■		■		■		TE-Y-HDA-ST 30 M16
									■				■		■		TE-Y-HDA-ST 37 M20

a) 1st gear

Anchor											Setting tool						
	TE 24 ^{a)}	TE 25 ^{a)}	TE 35	TE 40	TE 40 AVR	TE 56	TE 56-ATC	TE 60	TE 60-ATC	TE 70		TE 70-ATC	TE 75	TE 76	TE 76-ATC	TE 80-ATC	TE 80-ATC AVR
HDA-PR/TR20-M10x100/20	■		■	■													TE-C-HDA-ST 20 M10
						■		■									TE-Y-HDA-ST 20 M10
HDA-PR/TR 22-M12x125/30 HDA-PR/TR 22-M12x125/50	■		■	■													TE-C-HDA-ST 22 M12
	■		■	■		■		■									TE-Y-HDA-ST 22 M12
HDA-PR/TR 30-M16x190/40 HDA-PR/TR 30-M16x190/60									■		■		■		■		TE-Y-HDA-ST 30 M16

a) 1st gear

Anchor											Setting tool						
	TE 24 ^{a)}	TE 25 ^{a)}	TE 35	TE 40	TE 40 AVR	TE 56	TE 56-ATC	TE 60	TE 60-ATC	TE 70		TE 70-ATC	TE 75	TE 76	TE 76-ATC	TE 80-ATC	TE 80-ATC AVR
HDA-PF/TF 20-M10x100/20			■	■				■									TE-C-HDA-ST 20 M10
HDA-PF/TF 22-M12x125/30 HDA-PF/TF 22-M12x125/50			■	■				■									TE-C-HDA-ST 22 M12
HDA-PF/TF 30-M16x190/40 HDA-PF/TF 30-M16x190/60									■		■		■		■		TE-Y-HDA-ST 30 M16

a) 1st gear

Setting instruction

HDA-P, HDA-PR, HDA-PF

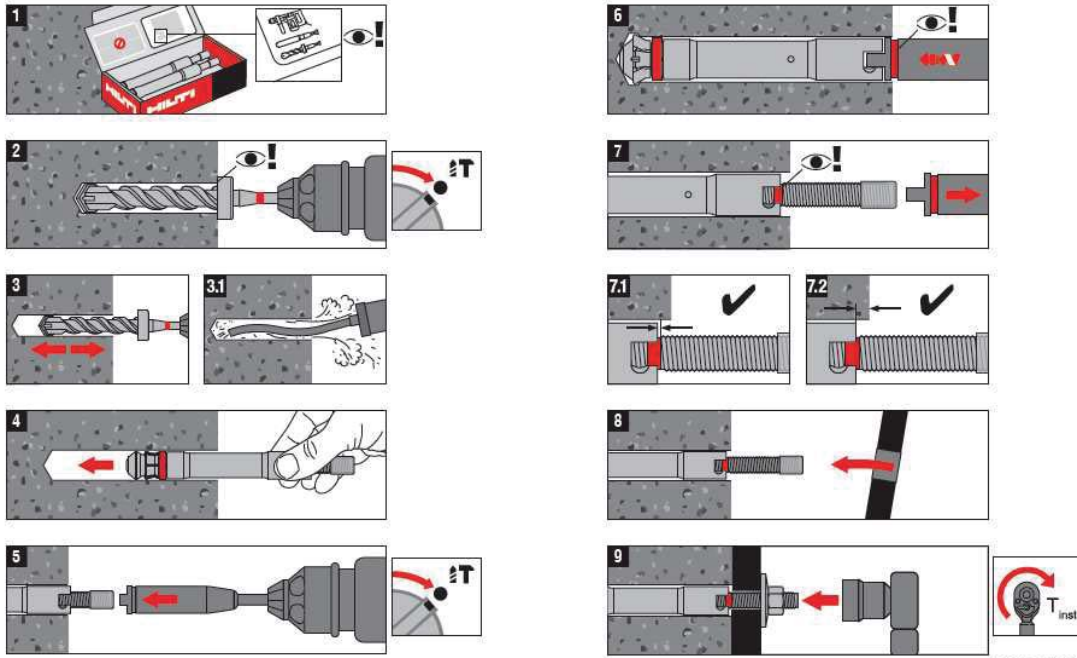

209616-A /05.07

HDA-T, HDA-TR, HDA-TF

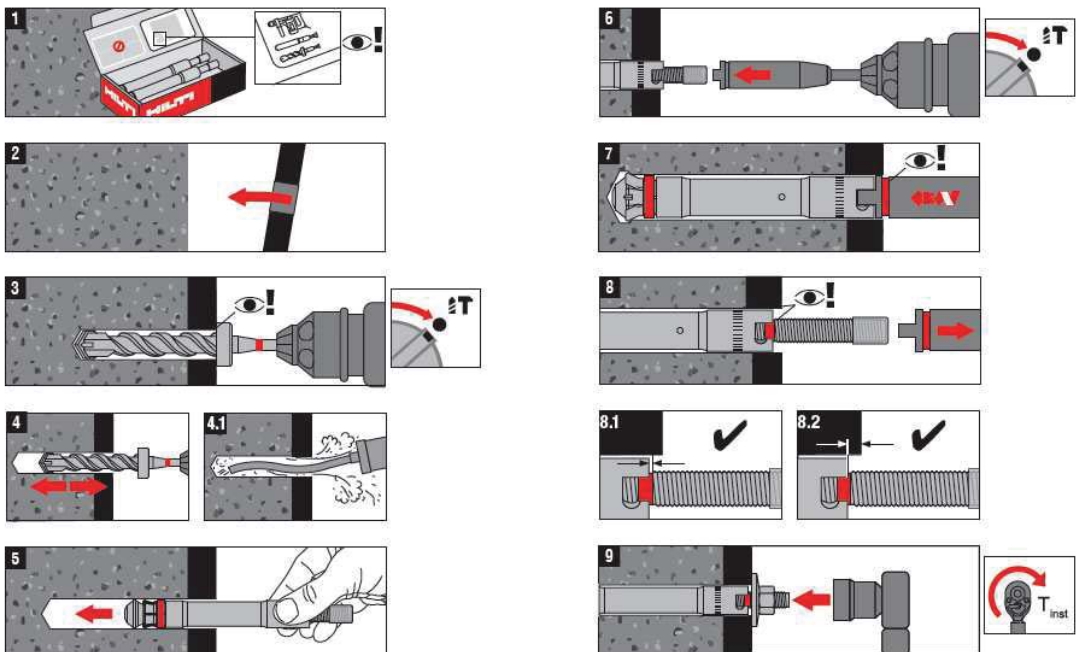

209617-A /05.07

HDA-F-CW, HDA-R-CW (to be set with HDA-T, HDA-TF, HDA-TR)

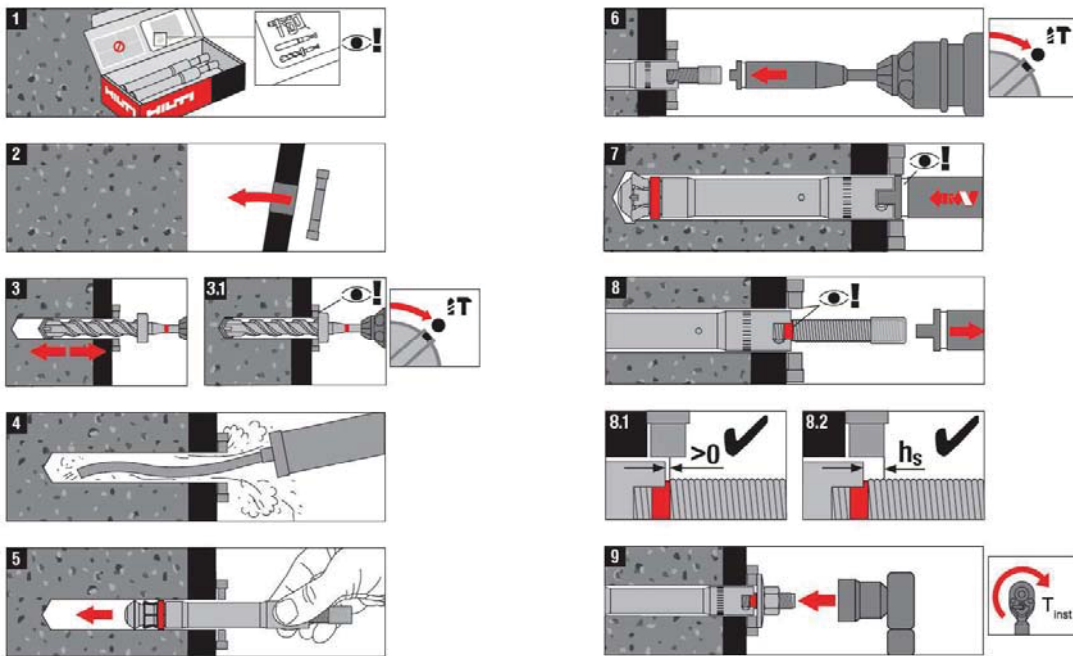

230285-A/11.07

For detailed information on installation see instruction for use given with the package of the product.

Setting details

HDA-P / HDA-PR / HDA-PF

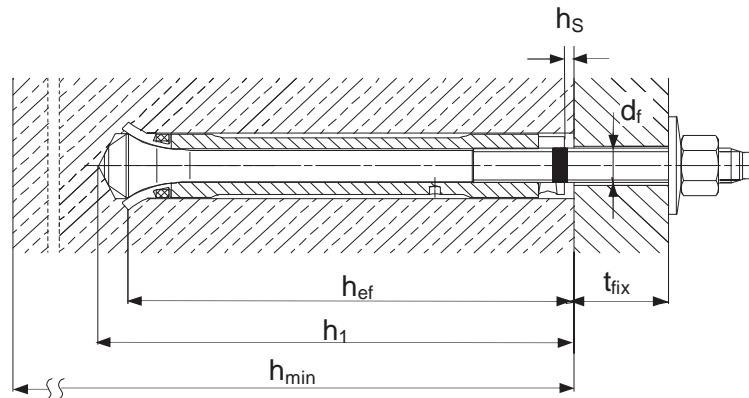

HDA-T / HDA-TR / HDA-TF

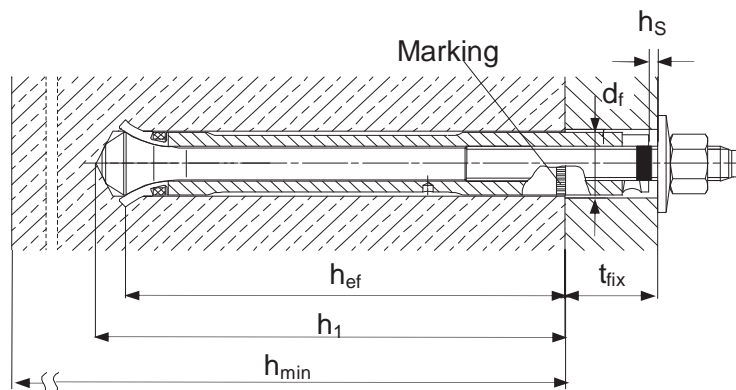

Anchor size			HDA-P / HDA-PR / HDA-PF / HDA-T / HDA-TR / HDA-TF							
			M10		M12		M16		M20	
			x100/20	x125/30	x125/50	x190/40	x190/60	x250/50	x250/100	
Head marking			I	L	N	R	S	V	X	
Nominal drill bit diameter	d_0	[mm]	20	22		30		37		
Cutting diameter of drill bit	$d_{cut,min}$	[mm]	20,10	22,10		30,10		37,15		
	$d_{cut,max}$	[mm]	20,55	22,55		30,55		37,70		
Depth of drill hole ^{a)}	$h_1 \geq$	[mm]	107	133		203		266		
Anchorage depth	h_{ef}	[mm]	100	125		190		250		
Sleeve recess	$h_{s,min}$	[mm]	2	2		2		2		
	$h_{s,max}$	[mm]	6	7		8		8		
Torque moment	T_{inst}	[Nm]	50	80		120		300		
For HDA-P/-PF/-PR										
Clearance hole	d_f	[mm]	12	14		18		22		
Minimum base material thickness	h_{min}	[mm]	180	200		270		350		
Fixture thickness	$t_{fix,min}$	[mm]	0	0		0		0		
	$t_{fix,max}$	[mm]	20	30	50	40	60	50	100	
For HDA-T/-TF/-TR										
Clearance hole	d_f	[mm]	21	23		32		40		
Minimum base material thickness	h_{min}	[mm]	200- t_{fix}	230- t_{fix}	250- t_{fix}	310- t_{fix}	330- t_{fix}	400- t_{fix}	450- t_{fix}	
Min. fixture thickness										
-Tension load only!	$t_{fix,min}$	[mm]	10	10		15		20	50	
-Shear load - without use of centering washer	$t_{fix,min}$	[mm]	15	15		20		25	50	
-Shear load - with use of centering washer	$t_{fix,min}$ ^{b)}	[mm]	10	10		15		20	-	
Max. fixture thickness	$t_{fix,max}$	[mm]	20	30	50	40	60	50	100	

a) use specified stop drill bit

b) with use of centering washer a reduction of $t_{fix,min}$ is possible for shear loading, details see ETA-99/0009

Setting parameters

Anchor size			HDA-P / HDA-PR / HDA-PF / HDA-T / HDA-TR / HDA-TF			
			M10 x100/20	M12 x125/30 x125/50	M16 x190/40 x190/60	
Minimum spacing	s_{min}	[mm]	100	125	190	250
Minimum edge distance	c_{min}	[mm]	80	100	150	200
Critical spacing for splitting failure	$s_{cr,sp}$	[mm]	300	375	570	750
Critical edge distance for splitting failure	$c_{cr,sp}$	[mm]	150	190	285	375
Critical spacing for concrete cone failure	$s_{cr,N}$	[mm]	300	375	570	750
Critical edge distance for concrete cone failure	$c_{cr,N}$	[mm]	150	190	285	375

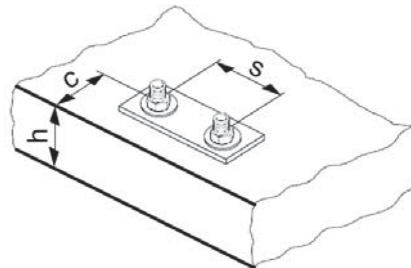

For spacing (edge distance) smaller than critical spacing (critical edge distance) the design loads have to be reduced.

Critical spacing and critical edge distance for splitting failure apply only for non-cracked concrete. For cracked concrete only the critical spacing and critical edge distance for concrete cone failure are decisive.

Simplified design method

Simplified version of the design method according ETAG 001, Annex C. Design resistance according data given in ETA-99/0009, issue 2010-12-17.

- Influence of concrete strength
- Influence of edge distance
- Influence of spacing
- Valid for a group of two anchors. (The method may also be applied for anchor groups with more than two anchors or more than one edge. The influencing factors must then be considered for each edge distance and spacing. The calculated design loads are then on the same side: They will be lower than the exact values according ETAG 001, Annex C. To avoid this, it is recommended to use the anchor design software PROFIS anchor)

The design method is based on the following simplification:

- No different loads are acting on individual anchors (no eccentricity)

The values are valid for one anchor.

For more complex fastening applications please use the anchor design software PROFIS Anchor.

Tension loading

The design tensile resistance is the lower value of

- Steel resistance: $N_{Rd,s}$
- Concrete pull-out resistance: $N_{Rd,p} = N_{Rd,p}^0 \cdot f_B$
- Concrete cone resistance: $N_{Rd,c} = N_{Rd,c}^0 \cdot f_B \cdot f_{1,N} \cdot f_{2,N} \cdot f_{3,N} \cdot f_{re,N}$
- Concrete splitting resistance (only non-cracked concrete):
 $N_{Rd,sp} = N_{Rd,c}^0 \cdot f_B \cdot f_{1,sp} \cdot f_{2,sp} \cdot f_{3,sp} \cdot f_{h,sp} \cdot f_{re,N}$

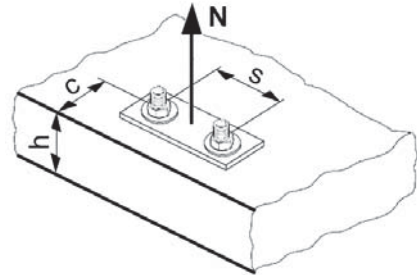

Basic design tensile resistance

Design steel resistance $N_{Rd,s}$

Anchor size		M10	M12	M16	M20 ^{a)}
$N_{Rd,s}$	HDA-P(F), HDA-T(F) [kN]	30,7	44,7	84,0	128,0
	HDA-PR, HDA-TR [kN]	28,8	41,9	78,8	-

a) HDA M20: only a galvanized 5 μ m version is available

Design pull-out resistance^{a)} $N_{Rd,p} = N_{Rd,p}^0 \cdot f_B$ (only in cracked concrete)

		Non-cracked concrete				Cracked concrete			
Anchor size		M10	M12	M16	M20 ^{b)}	M10	M12	M16	M20 ^{b)}
$N_{Rd,p}^0$	[kN]	-	-	-	-	16,7	23,3	50,0	63,3

a) Design pull-out resistance is not decisive in non-cracked concrete

b) HDA M20: only a galvanized 5 μ m version is available

Design concrete cone resistance $N_{Rd,c} = N_{Rd,c}^0 \cdot f_B \cdot f_{1,N} \cdot f_{2,N} \cdot f_{3,N} \cdot f_{re,N}$

Design splitting resistance^{a)} $N_{Rd,sp} = N_{Rd,c}^0 \cdot f_B \cdot f_{1,sp} \cdot f_{2,sp} \cdot f_{3,sp} \cdot f_{h,sp} \cdot f_{re,N}$

		Non-cracked concrete				Cracked concrete			
Anchor size		M10	M12	M16	M20 ^{b)}	M10	M12	M16	M20 ^{b)}
$N_{Rd,c}^0$	[kN]	38,7	54,1	101,4	153,1	27,7	38,7	72,5	109,3

a) Splitting resistance must only be considered for non-cracked concrete

b) HDA M20: only a galvanized 5 μ m version is available

Influencing factors

Influence of concrete strength

Concrete strength designation (ENV 206)	C 20/25	C 25/30	C 30/37	C 35/45	C 40/50	C 45/55	C 50/60
$f_B = (f_{ck,cube}/25N/mm^2)^{1/2}$ ^{a)}	1	1,1	1,22	1,34	1,41	1,48	1,55

a) $f_{ck,cube}$ = concrete compressive strength, measured on cubes with 150 mm side length

Influence of edge distance ^{a)}

$c/c_{cr,N}$	0,1	0,2	0,3	0,4	0,5	0,6	0,7	0,8	0,9	1
$c/c_{cr,sp}$										
$f_{1,N} = 0,7 + 0,3 \cdot c/c_{cr,N} \leq 1$	0,73	0,76	0,79	0,82	0,85	0,88	0,91	0,94	0,97	1
$f_{1,sp} = 0,7 + 0,3 \cdot c/c_{cr,sp} \leq 1$										
$f_{2,N} = 0,5 \cdot (1 + c/c_{cr,N}) \leq 1$	0,55	0,60	0,65	0,70	0,75	0,80	0,85	0,90	0,95	1
$f_{2,sp} = 0,5 \cdot (1 + c/c_{cr,sp}) \leq 1$										

a) The edge distance shall not be smaller than the minimum edge distance c_{min} given in the table with the setting details. These influencing factors must be considered for every edge distance.

Influence of anchor spacing ^{a)}

$s/s_{cr,N}$	0,1	0,2	0,3	0,4	0,5	0,6	0,7	0,8	0,9	1
$s/s_{cr,sp}$										
$f_{3,N} = 0,5 \cdot (1 + s/s_{cr,N}) \leq 1$	0,55	0,60	0,65	0,70	0,75	0,80	0,85	0,90	0,95	1
$f_{3,sp} = 0,5 \cdot (1 + s/s_{cr,sp}) \leq 1$										

a) The anchor spacing shall not be smaller than the minimum anchor spacing s_{min} given in the table with the setting details. This influencing factor must be considered for every anchor spacing.

Influence of base material thickness

h/h_{ef}	2	2,2	2,4	2,6	2,8	3	3,2	3,4	3,6	$\geq 3,68$
$f_{h,sp} = [h/(2 \cdot h_{ef})]^{2/3}$	1	1,07	1,13	1,19	1,25	1,31	1,37	1,42	1,48	1,5

Influence of reinforcement

Anchor size	M10	M12	M16	M20
$f_{re,N} = 0,5 + h_{ef}/200mm \leq 1$	1			

Shear loading

The design shear resistance is the lower value of

- Steel resistance: $V_{Rd,s}$
- Concrete pryout resistance: $V_{Rd,cp} = k \cdot N_{Rd,c}$
- Concrete edge resistance: $V_{Rd,c} = V_{Rd,c}^0 \cdot f_B \cdot f_{fB} \cdot f_h \cdot f_4 \cdot f_{hef} \cdot f_c$

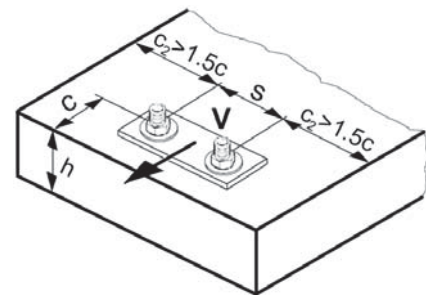

Basic design shear resistance

Design steel resistance $V_{Rd,s}$

Anchor size		M10	M12	M16	M20 ^{a)}
$V_{Rd,s}$	HDA-P, HDA-PF [kN]	17,6	24,0	49,6	73,6
	HDA-PR [kN]	17,3	25,6	47,4	-
	HDA-T, HDA-TF ^{b)} [kN]	43,3	53,3	93,3	136,7
	HDA-TR ^{b)} [kN]	53,4	65,4	114,3	-

a) HDA M20: only a galvanized 5 μ m version is available

b) Values are valid for minimum thickness of the base plate $t_{fix,min}$. For characteristic resistance to shear loads with thicker base plates see ETA-99/0009 or use PROFIS software.

Design concrete pryout resistance $V_{Rd,cp} = k \cdot N_{Rd,c}$ ^{a)}

Anchor size	M10	M12	M16	M20
k	2,0			

a) $N_{Rd,c}$: Design concrete cone resistance

Design concrete edge resistance^{a)} $V_{Rd,c} = V_{Rd,c}^0 \cdot f_B \cdot f_h \cdot f_4 \cdot f_{hef} \cdot f_c$

Anchor size	Non-cracked concrete				Cracked concrete			
	M10	M12	M16	M20 ^{b)}	M10	M12	M16	M20 ^{b)}
$V_{Rd,c}^0$ [kN]	25,1	29,8	51,1	70,0	17,8	21,1	36,2	49,6

a) For anchor groups with more than two anchors only the anchors close to the edge must be considered.

b) HDA M20: only a galvanized 5 μ m version is available

Influencing factors

Influence of concrete strength

Concrete strength designation (ENV 206)	C 20/25	C 25/30	C 30/37	C 35/45	C 40/50	C 45/55	C 50/60
$f_B = (f_{ck,cube}/25N/mm^2)^{1/2}$ ^{a)}	1	1,1	1,22	1,34	1,41	1,48	1,55

a) $f_{ck,cube}$ = concrete compressive strength, measured on cubes with 150 mm side length

Influence of angle between load applied and the direction perpendicular to the free edge

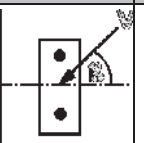
Angle β	0°	10°	20°	30°	40°	50°	60°	70°	80°	$\geq 90^\circ$
$f_\beta = \frac{1}{\sqrt{(\cos \alpha_v)^2 + \left(\frac{\sin \alpha_v}{2,5}\right)^2}}$ 	1	1,01	1,05	1,13	1,24	1,40	1,64	1,97	2,32	2,50

Influence of base material thickness

h/c	0,15	0,3	0,45	0,6	0,75	0,9	1,05	1,2	1,35	$\geq 1,5$
$f_h = \{h/(1,5 \cdot c)\}^{1/2} \leq 1$	0,32	0,45	0,55	0,63	0,71	0,77	0,84	0,89	0,95	1,00

Influence of anchor spacing and edge distance ^{a)} for concrete edge resistance: f_4

$$f_4 = (c/h_{ef})^{1,5} \cdot (1 + s / [3 \cdot c]) \cdot 0,5$$

c/h _{ef}	Single anchor	Group of two anchors s/h _{ef}														
		0,75	1,50	2,25	3,00	3,75	4,50	5,25	6,00	6,75	7,50	8,25	9,00	9,75	10,50	11,25
0,50	0,35	0,27	0,35	0,35	0,35	0,35	0,35	0,35	0,35	0,35	0,35	0,35	0,35	0,35	0,35	0,35
0,75	0,65	0,43	0,54	0,65	0,65	0,65	0,65	0,65	0,65	0,65	0,65	0,65	0,65	0,65	0,65	0,65
1,00	1,00	0,63	0,75	0,88	1,00	1,00	1,00	1,00	1,00	1,00	1,00	1,00	1,00	1,00	1,00	1,00
1,25	1,40	0,84	0,98	1,12	1,26	1,40	1,40	1,40	1,40	1,40	1,40	1,40	1,40	1,40	1,40	1,40
1,50	1,84	1,07	1,22	1,38	1,53	1,68	1,84	1,84	1,84	1,84	1,84	1,84	1,84	1,84	1,84	1,84
1,75	2,32	1,32	1,49	1,65	1,82	1,98	2,15	2,32	2,32	2,32	2,32	2,32	2,32	2,32	2,32	2,32
2,00	2,83	1,59	1,77	1,94	2,12	2,30	2,47	2,65	2,83	2,83	2,83	2,83	2,83	2,83	2,83	2,83
2,25	3,38	1,88	2,06	2,25	2,44	2,63	2,81	3,00	3,19	3,38	3,38	3,38	3,38	3,38	3,38	3,38
2,50	3,95	2,17	2,37	2,57	2,77	2,96	3,16	3,36	3,56	3,76	3,95	3,95	3,95	3,95	3,95	3,95
2,75	4,56	2,49	2,69	2,90	3,11	3,32	3,52	3,73	3,94	4,15	4,35	4,56	4,56	4,56	4,56	4,56
3,00	5,20	2,81	3,03	3,25	3,46	3,68	3,90	4,11	4,33	4,55	4,76	4,98	5,20	5,20	5,20	5,20
3,25	5,86	3,15	3,38	3,61	3,83	4,06	4,28	4,51	4,73	4,96	5,18	5,41	5,63	5,86	5,86	5,86
3,50	6,55	3,51	3,74	3,98	4,21	4,44	4,68	4,91	5,14	5,38	5,61	5,85	6,08	6,31	6,55	6,55
3,75	7,26	3,87	4,12	4,36	4,60	4,84	5,08	5,33	5,57	5,81	6,05	6,29	6,54	6,78	7,02	7,26
4,00	8,00	4,25	4,50	4,75	5,00	5,25	5,50	5,75	6,00	6,25	6,50	6,75	7,00	7,25	7,50	7,75
4,25	8,76	4,64	4,90	5,15	5,41	5,67	5,93	6,18	6,44	6,70	6,96	7,22	7,47	7,73	7,99	8,25
4,50	9,55	5,04	5,30	5,57	5,83	6,10	6,36	6,63	6,89	7,16	7,42	7,69	7,95	8,22	8,49	8,75
4,75	10,35	5,45	5,72	5,99	6,27	6,54	6,81	7,08	7,36	7,63	7,90	8,17	8,45	8,72	8,99	9,26
5,00	11,18	5,87	6,15	6,43	6,71	6,99	7,27	7,55	7,83	8,11	8,39	8,66	8,94	9,22	9,50	9,78
5,25	12,03	6,30	6,59	6,87	7,16	7,45	7,73	8,02	8,31	8,59	8,88	9,17	9,45	9,74	10,02	10,31
5,50	12,90	6,74	7,04	7,33	7,62	7,92	8,21	8,50	8,79	9,09	9,38	9,67	9,97	10,26	10,55	10,85

a) The anchor spacing and the edge distance shall not be smaller than the minimum anchor spacing s_{min} and the minimum edge distance c_{min} .

Influence of embedment depth

Anchor size	M10	M12	M16	M20
$f_{hef} = 0,05 \cdot (h_{ef} / d)^{1,68}$	0,81	1,00	1,18	1,36

Influence of edge distance ^{a)}

c/d	4	6	8	10	15	20	30	40
$f_c = (d / c)^{0,19}$	0,77	0,71	0,67	0,65	0,60	0,57	0,52	0,50

a) The edge distance shall not be smaller than the minimum edge distance c_{min} .

Combined tension and shear loading

For combined tension and shear loading see section "Anchor Design".

Precalculated values

Design resistance calculated according ETAG 001, Annex C and data given in ETA-99/0009, issue 2010-12-17. All data applies to concrete C 20/25 – $f_{ck,cube} = 25$ N/mm². HDA-PF and HDA-TF anchors are not covered by the approval. For HDA-T and HDA-TR anchors the resistance to shear loads is calculated for the minimum thickness of the base plate given in chapter setting details.

Recommended loads can be calculated by dividing the design resistance by an overall partial safety factor for action $\gamma = 1,4$. The partial safety factors for action depend on the type of loading and shall be taken from national regulations.

Design resistance

Single anchor, no edge effects, shear without lever arm

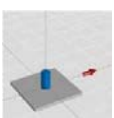
		Non-cracked concrete				Cracked concrete				
Anchor size		M10	M12	M16	M20	M10	M12	M16	M20	
Min. base material thickness h_{\min} [mm]		180	200	270	350	180	200	270	350	
HDA-T: Min. fixture thickness t_{fix} [mm]		15	15	20	25	15	15	20	25	
	Tensile N_{Rd}									
	HDA-P(F), HDA-T(F)	[kN]	30,7	44,7	84,0	128,0	16,7	23,3	50,0	63,3
	HDA-PR, HDA-TR	[kN]	28,8	41,9	78,8	-	16,7	23,3	50,0	-
	Shear V_{Rd}									
	HDA-P, HDA-PF	[kN]	17,6	24,0	49,6	73,6	17,6	24,0	49,6	73,6
	HDA-PR	[kN]	17,3	25,6	47,4	-	17,3	25,6	47,4	-
	HDA-T, HDA-TF	[kN]	43,3	53,3	93,3	136,7	43,3	53,3	93,3	136,7
	HDA-TR	[kN]	53,4	65,4	114,3	-	53,4	65,4	114,3	-

Single anchor, min. edge distance ($c = c_{\min}$), shear without lever arm

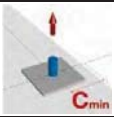
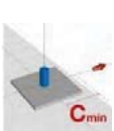
		Non-cracked concrete				Cracked concrete				
Anchor size		M10	M12	M16	M20	M10	M12	M16	M20	
Min. base material thickness h_{\min} [mm]		180	200	270	350	180	200	270	350	
HDA-T: Min. fixture thickness t_{fix} [mm]		15	15	20	25	15	15	20	25	
Min. edge distance c_{\min} [mm]		80	100	150	200	80	100	150	200	
	Tensile N_{Rd}									
	HDA-P(F), HDA-T(F) HDA-PR, HDA-TR	[kN]	25,5	35,9	66,4	100,9	16,7	23,3	47,4	63,3
	Shear V_{Rd}									
	HDA-P, HDA-PF	[kN]	10,4	14,8	26,4	41,8	7,3	10,5	18,7	29,6
	HDA-PR	[kN]	10,4	14,8	26,4	41,8	7,3	10,5	18,7	29,6
	HDA-T, HDA-TF	[kN]	10,4	14,8	26,4	41,8	7,3	10,5	18,7	29,6
	HDA-TR	[kN]	10,4	14,8	26,4	41,8	7,3	10,5	18,7	29,6

Double anchor, no edge effects, min. spacing ($s = s_{\min}$), shear without lever arm (load values are valid for one anchor)

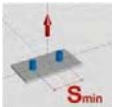
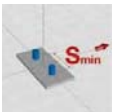
		Non-cracked concrete				Cracked concrete				
Anchor size		M10	M12	M16	M20	M10	M12	M16	M20	
Min. base material thickness h_{\min} [mm]		180	200	270	350	180	200	270	350	
HDA-T: Min. fixture thickness t_{fix} [mm]		15	15	20	25	15	15	20	25	
Min. spacing s_{\min} [mm]		100	125	190	250	100	125	190	250	
	Tensile N_{Rd}									
	HDA-P(F), HDA-T(F) HDA-PR, HDA-TR	[kN]	25,8	36,0	67,6	102,1	16,7	23,3	48,3	63,3
	Shear V_{Rd}									
	HDA-P, HDA-PF	[kN]	17,6	24,0	49,6	73,6	17,6	24,0	49,6	73,6
	HDA-PR	[kN]	17,3	25,6	47,4	-	17,3	25,6	47,4	-
	HDA-T, HDA-TF	[kN]	43,3	53,3	93,3	136,7	36,9	51,4	93,3	136,7
	HDA-TR	[kN]	51,6	65,4	114,3	-	36,9	51,4	96,6	-