

## HUS 6 Screw anchor, Redundant fastening

	Anchor version	Benefits
	HUS-A 6 Carbon steel Concrete Screw with hex head	- Quick and easy setting - Low expansion forces in base materials
	HUS-H 6 Carbon steel Concrete Screw with hex head	- Through fastening - Removable
	HUS-I 6 Carbon steel Concrete Screw with hex head	- Forged-on washer and hexagon head with no protruding thread
	HUS-P 6 Carbon steel Concrete Screw with pan head	
	HUS-HR 6 Stainless steel Concrete Screw	

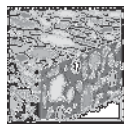

Concrete



Tensile  
zone

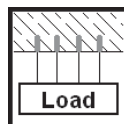

Redundant  
fastening



Small edge  
distance  
and spacing



Fire  
resistance



Corrosion  
Resistance



European  
Technical  
Approval



CE  
conformity

### Approvals / certificates

Description	Authority / Laboratory	No. / date of issue
European technical approval <sup>a)</sup>	DIBt, Berlin	ETA-10/0005 / 2011-08-23
Fire test report	DIBt, Berlin	ETA-10/0005 / 2011-08-23

a) Data for HUS-HR 6 with nominal embedment depth = 30 mm for multiple use for non-structural applications (= redundant fastening) are not part of ETA-10/0005 issue 2011-08-23

### Basic loading data

All data in this section applies to

- Correct setting (See setting instruction)
- No edge distance and spacing influence
- Concrete C 20/25,  $f_{ck,cube} = 25 \text{ N/mm}^2$

For details see Simplified design method

The following technical data are based on:

**ETA:** Data according ETA-05/0005 issue 2011-08-23

**Hilti:** Additional Hilti technical data

**Characteristic resistance**

				Hilti tech. data	Data according ETA-10/0005, issue 2011-08-23		
Anchor version				HUS-HR 6		HUS-A, -H, -I, -P 6	
Nominal embedment depth		$h_{nom}$	[mm]	30	35	35	
All load directions	$35 \leq c < 80$ mm	$F_{Rk}^0$	[kN]	2,0	3,0	2,0	
	$c \geq 80$ mm	$F_{Rk}^0$	[kN]		5,0	3,0	

**Design resistance**

				Hilti tech. data	Data according ETA-10/0005, issue 2011-08-23		
Anchor version				HUS-HR 6		HUS-A, -H, -I, -P 6	
Nominal embedment depth		$h_{nom}$	[mm]	30	35	35	
All load directions	$35 \leq c < 80$ mm	$F_{Rd}^0$	[kN]	1,0	1,4	1,3	
	$c \geq 80$ mm	$F_{Rd}^0$	[kN]		2,4	2,0	

**Recommended loads**

				Hilti tech. data	Data according ETA-10/0005, issue 2011-08-23		
Anchor version				HUS-HR 6		HUS-A, -H, -I, -P 6	
Nominal embedment depth		$h_{nom}$	[mm]	30	35	35	
All load directions <sup>a)</sup>	$35 \leq c < 80$ mm	$F_{Rec}^0$	[kN]	0,7	1,0	0,9	
	$c \geq 80$ mm	$F_{Rec}^0$	[kN]		1,7	1,4	

a) With overall partial safety factor for action  $\gamma = 1,4$ . The partial safety factors for action depend on the type of loading and shall be taken from national regulations.

**Requirements for redundant fastening**

The definition of redundant fastening according to Member States is given in the ETAG 001 Part six, Annex 1. In absence of a definition by a Member State the following default values may be taken

Minimum number of fixing points	Minimum number of anchors per fixing point	Maximum design load of action $N_{Sd}$ per fixing point <sup>a)</sup>
3	1	2 kN
4	1	3 kN

a) The value for maximum design load of actions per fastening point  $N_{Sd}$  is valid in general that means all fastening points are considered in the design of the redundant structural system. The value  $N_{Sd}$  may be increased if the failure of one (= most unfavourable) fixing point is taken into account in the design (serviceability and ultimate limit state) of the structural system e.g. suspended ceiling.

## Materials

### Mechanical properties

Anchor version			HUS-HR 6	HUS-A, -H, -I, -P 6
Nominal tensile strength	$f_{uk}$	[N/mm <sup>2</sup> ]	1040	930
Stressed cross-section	$A_s$	[mm <sup>2</sup> ]	23	26,9
Moment of resistance	$W$	[mm <sup>3</sup> ]	15,5	19,7
Design bending resistance	$M_{Rd,s}$	[Nm]	12,9	14,6

### Material quality

Anchor version			HUS-HR 6	HUS-A, -H, -I, -P 6
Material			Stainless steel (grade A4)	Steel, Galvanised $\geq 5 \mu\text{m}$

## Anchor dimensions

### Dimensions

Anchor version			HUS-HR 6	HUS-A 6	HUS-H 6	HUS-I 6	HUS-P 6
Nominal length	$l_s$	[mm]	35 ... 70	35	40..120	35	40..80
Outer diameter of thread	$d_s$	[mm]	7,6	7,85			
Core diameter	$d_k$	[mm]	5,4	5,85			

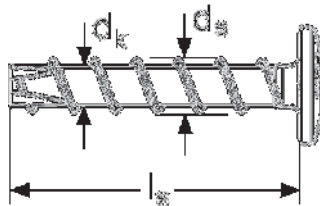

### Head configuration

<b>HUS-A 6</b>	External thread M8 or M10		
		Square mark with $d = 2 \text{ mm}$ edge length for $h_{\text{nom}} = 35 \text{ mm}$	
<b>HUS-H 6</b>	Hex head and Torx T30		
<b>HUS-I 6</b>	Internal threads M8 and M10		
		One circle mark with $d = 0.8 \text{ mm}$ for $h_{\text{nom}} = 35 \text{ mm}$	
<b>HUS-P 6</b>	Pan head with		
<b>HUS-HR 6</b>	Hexagon head SW = 13 mm		

### Setting

#### Recommended installation equipment

Anchor size	HUS-HR 6	HUS-A 6	HUS-I 6	HUS-H 6	HUS-P 6
Rotary hammer	Hilti TE 6 / TE 7				
drill bit	TE-CX 6				
Socket wrench insert	S-NSD 13 ½ (L)	S-NSD 13 ½ L	S-NSD 13 ½ (L)		-
Torx	-			T30	
Impact screw driver	See setting instruction				

Setting instruction

HUS-HR 6

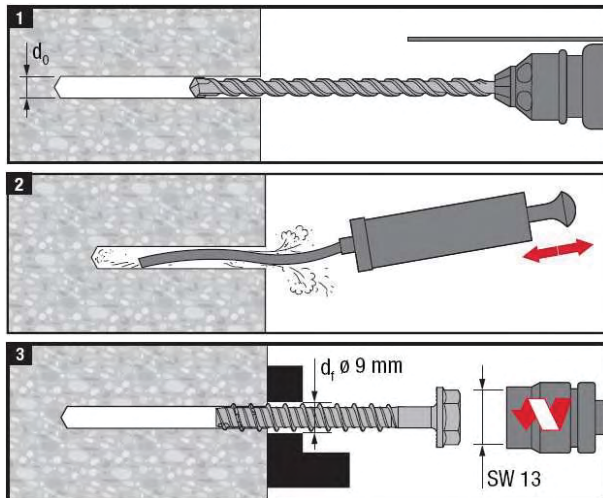
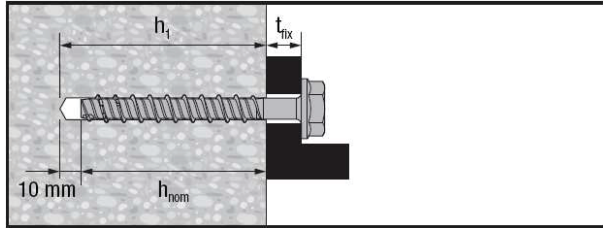

3.1

	$h_{nom}$ 30 mm	35 mm	55 mm	55 mm	55 mm
SIW/SID 121	✓	✓	✓	✗	✗
SIW/SID 144	✓	✓	✓	✗	✗
SIW 22T-A	✗	✗	✗	✗	✗
SI 100	✗	✗	✗	✗	✗
TKI 2500	✓	✓	✓	✗	✗
⊙	✗	✗	✗	12 Nm	6 Nm

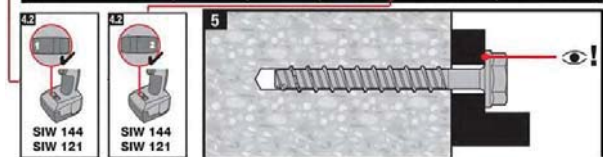

HUS-P 6, HUS-I 6

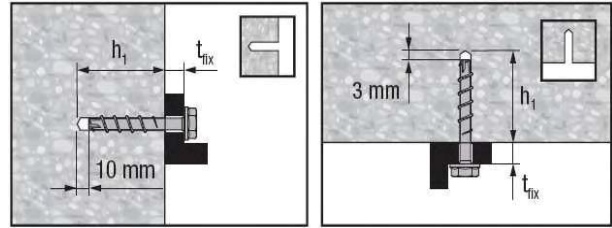

reduced drilling depth  
for overhead installation

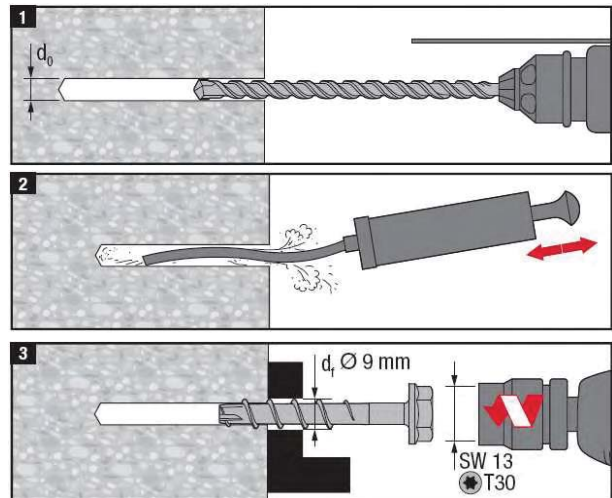

3.1

SIW/SID 121	✓
SIW/SID 144	✓
TKI 2500	✓
⊙	18 Nm

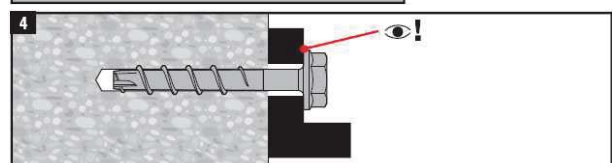

For detailed information on installation see instruction for use given with the package of the product.

### Setting details

Anchor version		HUS-HR 6		HUS-A 6	HUS-H 6	HUS-I 6	HUS-P 6
Nominal embedment depth	$h_{nom} \geq$ [mm]	30	35	35			
Nominal diameter of drill bit	$d_o$ [mm]	6					
Cutting diameter of drill bit	$d_{cut} \leq$ [mm]	6,4					
Depth of drill hole	$h_1 \geq$ [mm]	40	45	45			
Depth of drill hole for overhead installation	$h_1 \geq$ [mm]	40	45	38			
Diameter of clearance hole in the fixture	$d_f \leq$ [mm]	9		-	9	-	9
Effective anchorage depth	$h_{ef}$ [mm]	23	27	25			
Nominal length of screw	$l_s$ [mm]	35 ... 70	60 ... 70	35	40 ... 120	35	40 ... 80
Max. fastening thickness	$t_{fix}$ [mm]	$l_s - h_{nom}$		-	$l_s - h_{nom}$	-	$l_s - h_{nom}$
Max. installation torque	$T_{inst}$ [Nm]	- a)	- a)	18			

a) Hilti recommends machine setting only

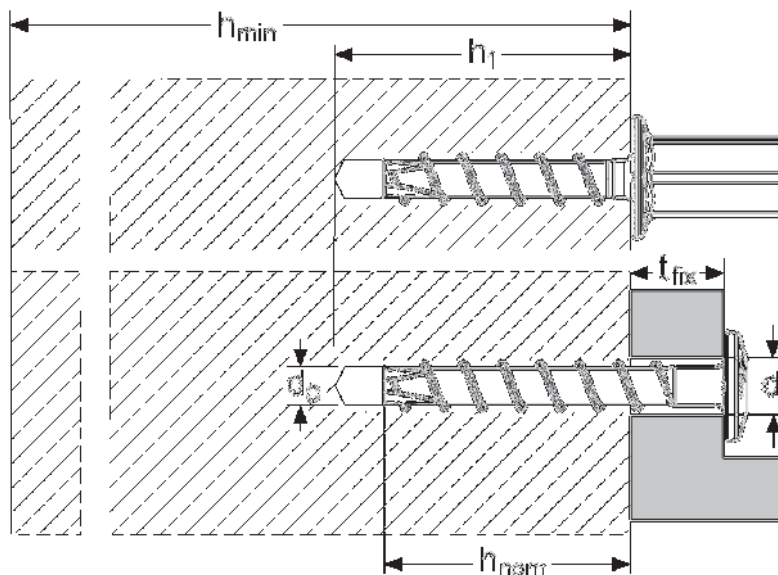

### Base material thickness, anchor spacing and edge distance

Anchor version			HUS-HR 6		HUS-A, -H, -I, -P 6
Nominal embedment depth	$h_{nom}$	[mm]	30	35	35
Effective anchorage depth	$h_{ef}$	[mm]	23	27	25
Minimum base material thickness	$h_{min}$	[mm]	80	80	80
Minimum spacing	$s_{min}$	[mm]	35	35	35
Minimum edge distance	$c_{min}$	[mm]	35	35 (80) <sup>1)</sup>	35 (80) <sup>1)</sup>
Critical spacing	$s_{cr}$	[mm]	3 $h_{ef}$		
Critical edge distance	$c_{cr}$	[mm]	1,5 $h_{ef}$		

<sup>1)</sup> see basic loading data

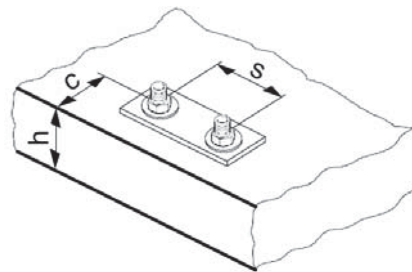

For spacing (edge distance) smaller than critical spacing (critical edge distance) the design loads have to be reduced (see system design resistance).

### Simplified design method for multiple use for non-structural applications (= redundant fastening)

Simplified version of the design method according ETAG 001, Annex C. Design resistance according data given in ETA-10/0005 issue 2011-08-23.

- Influence of concrete strength
- Influence of edge distance
- Influence of spacing
- Valid for a group of two anchors. (The method may also be applied for anchor groups with more than two anchors or more than one edge. The influencing factors must then be considered for each edge distance and spacing. The calculated design loads are then on the save side: They will be lower than the exact values according ETAG 001, Annex C.

The design method is based on the following simplification:

- No different loads are acting on individual anchors (no eccentricity)

The values are valid for one anchor.



### Design load – all load directions

**Design resistance**  $F_{Rd} = F_{Rd}^0 \cdot f_B \cdot f_1 \cdot f_2 \cdot f_3 \cdot f_{re}$

### Basic design resistance

		Hilti tech. data	Data according ETA-10/0005, issue 2011-08-23	
Anchor version		HUS-HR 6	HUS-A, -H, -I, -P 6	
Nominal embedment depth	$h_{nom}$ [mm]	30	35	35
Basic design resistance in all load directions	$35 \leq c < 80$ mm	1,0	1,4	1,3
	$c \geq 80$ mm		2,4	2,0

### Influencing factors

#### Influence of concrete strength

Concrete strength designation (ENV 206)	C 20/25	C 25/30	C 30/37	C 35/45	C 40/50	C 45/55	C 50/60
$f_B = (f_{ck,cube}/25N/mm^2)^{0,5}$ a)	1	1,1	1,22	1,34	1,41	1,48	1,55

a)  $f_{ck,cube}$  = concrete compressive strength, measured on cubes with 150 mm side length

#### Influence of edge distance a)

$c/c_{cr}$	0,1	0,2	0,3	0,4	0,5	0,6	0,7	0,8	0,9	1
$f_1 = 0,7 + 0,3 \cdot c/c_{cr} \leq 1$	0,73	0,76	0,79	0,82	0,85	0,88	0,91	0,94	0,97	1
$f_2 = 0,5 \cdot (1 + c/c_{cr}) \leq 1$	0,55	0,60	0,65	0,70	0,75	0,80	0,85	0,90	0,95	1

a) The edge distance shall not be smaller than the minimum edge distance  $c_{min}$  given in the table with the setting details. The influencing factors must be considered for every edge distance.

#### Influence of anchor spacing a)

$s/s_{cr}$	0,1	0,2	0,3	0,4	0,5	0,6	0,7	0,8	0,9	1
$f_3 = 0,5 \cdot (1 + s/s_{cr}) \leq 1$	0,55	0,60	0,65	0,70	0,75	0,80	0,85	0,90	0,95	1

a) The anchor spacing shall not be smaller than the minimum anchor spacing  $s_{min}$  given in the table with the setting details. This influencing factor must be considered for every anchor spacing.

#### Influence of reinforcement

$h_{nom}$ [mm]	Dense reinforcement		Standard reinforcement a)	
	30	35	30	35
$f_{re} = 0,5 + h_{ef}/200mm \leq 1$	0,62	0,63	1	

a) If in the area of anchorage there is reinforcement with a spacing  $\geq 150$  mm (any diameter) or with a diameter  $\leq 10$  mm and a spacing  $\geq 100$  mm, then a factor  $f_{re,N} = 1$  may be applied.