



Pipe Shoes

Technical Data

Version 1.6
November 2023



INDEX

Content	Page
CHANGE HISTORY	3
GENERAL INFORMATION	4
MATERIAL PROPERTIES	5
PIPE SHOE MP-PS L1-1	6
PIPE SHOE MP-PS M1-1	10
PIPE SHOE MP-PS H1-1	14
PIPE SHOE MP-PS L2-2	18
PIPE SHOE MP-PS M2-2	22
PIPE SHOE MP-PS H2-2	26
PIPE SHOE MP-PS L4-2	30
PIPE SHOE MP-PS M4-2	34
PIPE SHOE MP-PS H4-2	38
PIPE SHOES CLAMP ORIENTATION	42
WELDABLE PIPE SHOE MP-PS M2-W	43
INSULATING BANDS	45
MT-FPS-FF OC	50
MT-FPS-FZL OC	51
MT-FPS-SF OC	52
MT-FPS-SZ1 OC	53
MT-FPS-SZ2 OC	54
MT-FPS-GF OC	55
MT-FPS-GL1 OC	56
MT-FPS-GL2 OC	57
MIA-BO90/120-M12	58
MI-DGC 90	59
MI-DGC 120	60
MIC-PS90/120	61
MP-PS IXG	62
ADAPTER PLATE MT-FPS-AP OC	66
SLIDER PLATE MT-SP OC	67

GENERAL INFORMATION FOR LOAD TABLES

A probabilistic approach is followed when testing is used to derive allowable loads, design strength, and limit state values utilizing safety factors and resistance values as applicable. Published technical data loading tables are based on static loading conditions only. All non-static forces must be considered separately. Service loads were not considered.

The tabulated values for the pipe shoes and connectors as listed in this product technical guide are a combination of physical tests and analytical calculations. They do not include local effects, bending, web crippling, shear or buckling of a supporting member. These limit states must be checked independently. See table below for applicable failure modes (limit states) that govern per loading direction for each item.

The point of load application for determination of applicable values is at the centerline of the pipe axis (X-Asix) as can be seen in the following diagram:



Item	+/- FX	+/- FY	+ F	- FZ
MP-PS 1-1	Deformation of pipe ring	Deformation of baseplate	Ultimate strength of baseplate	Ultimate strength of baseplate OR Ultimate strength of MT-TFB
MP-PS 2-2 MP-PS 4-2	Deformation of baseplate	Deformation of baseplate OR Ultimate strength of MT-TFB		
MT-FPS-FF	Deformation of bracket	Deformation of baseplate	-	Deformation of baseplate
MT-FPS-FZL	Deformation of bracket	Deformation of baseplate	-	Deformation of bracket
MP-PS-IFG/ISG	Slip of jaws	Slip of jaws OR Deformation of baseplate	-	Deformation of baseplate
MT-FPS-SF	-	Deformation of bracket	-	Deformation of bracket
MT-FPS-GF	-	Deformation of bracket	-	-
MT-FPS-SZ1 MT-FPS-SZ2	-	Deformation of bracket	-	Deformation of bracket
MT-FPS-GL1 MT-FPS-GL2	-	Deformation of bracket	-	-

List of standards used in load tables

#	Standard Name	Standard Code	Details
American standards			
1	Standard Test Method for Static and Kinetic Coefficients of Friction of Plastic Film and Sheeting	ASTM D1894-14	
2	Standard test method for rubber property	ASTM D2240	Durometer hardness
European standards			
1	Hot rolled products of structural steels	DIN EN 10025-2	Part 2: Technical delivery conditions for non-alloy structural steels
2	Continuously hot-dip coated steel flat products	DIN EN 10346	Technical delivery conditions
3	Eurocode - Basis of structural design	EN 1993:2002/ A1:2005	
4	Eurocode 3: Design of steel structures	EN 1993-1-1 EN 1993-1-2	Part 1.1 General rules and rules for buildings Part 1-2: General rules - Structural fire design
5	Metallic industrial piping	EN13480-3	Part 3: Design and calculation
6	Rohrhalterungen	VGB R 510	
7	Founding - Malleable cast irons	DIN EN 1562	
8	Stainless steel	DIN EN 10088-3	Part 3: Technical delivery conditions for semi-finished products, bars, rods and sections for general purposes
9	Cold-rolled narrow steel strip for heat-treatment - Technical delivery conditions	DIN EN 10132-3	Part 1: Steels for quenching and tempering
10	Mechanical properties of fasteners made of carbon steel and alloy steel	DIN EN ISO 898-1	Part 1: Bolts, screws and studs with specified property classes - Coarse thread and fine pitch thread (ISO 898-1:2013)
		DIN EN ISO 898-2	Part 2: Nuts with specified property classes - Coarse thread and fine pitch thread (ISO 898-2:2012)
11	Hot dip galvanized coatings on fabricated iron and steel articles	ISO 1461	Specification and test methods
12	Fasteners - Hot dip galvanized coatings	EN ISO 10684:2004	
13	Fasteners - Non-electrolytically applied zinc flake coatings	DIN EN ISO 10683	

MATERIAL PROPERTIES^{1,2}

Component	Material (Reference)	F _y Yield strength N/mm ²	F _u Tensile strength, N/mm ²	E Modulus of elasticity N/mm ²	G Shear modulus N/mm ²
Pipe ring Midplate MT-FPS-FZL Rectangular washer (MP-PS IFG/ISG)	S235JR (DIN EN 10025-2)	235	360	210000	80769
Baseplate Baseplate (MP-PS IFG/ISG) Serrated washer MT-FPS-FF MT-FPS-SF MT-FPS-GF MT-FPS-SZ1 MT-FPS-SZ2 MT-FPS-GL1 MT-FPS-GL2	S280GD (EN 10346)	280	360		
Bolts Nuts	F Class 8.8 (ISO 898-1) Grade 8 (ISO 898-2)	640	800		
Beam Clamp (MP-PS IFG/ISG)	Cast Iron (DIN EN 1562)	270	450		
Cylindrical washers (MP-PS IFG)	Stainless Steel X5CrNi8-10 (EN 10088-3)	190	500		
Retaining washers (MP-PS IFG/ISG)	C60E (EN10132-3)	450	750		
Sliding plates PA66-GF30	Static friction coefficient values per ASTM D1894-14: Hot Dip Galvanized mating surface: 0.13 Zinc-Magnesium mating surface: 0.15 Zinc Plated mating surface: 0.18				

1 Capacities provided throughout this product technical guide are based on each product at an assumed room temperature of 20 °C (68 °F)

2 Unless otherwise noted in the Information for Use (IFU) do NOT weld the products listed within this product technical guide

ABBREVIATIONS

The following abbreviations are used throughout this product technical guide:

- NPS = Nominal Pipe Size
- D = Outer Pipe Diameter
- H_{Base} = Distance from bottom of support to bottom of pipe clamp
- H_{Center} = Distance from bottom of support to centerline of pipe axis
- H_{Max} = Distance from bottom of support to top of upper pipe clamp
- E_{exp} = Expected
- R_{rec} = Recommended

PIPE SHOE MP-PS L1-1

General

Media temperature limits: -20 °C to +300 °C

Height adjustability: 88.5 - 116 mm (with sliding plate)
85.5 - 113 mm (without sliding plate)

Slope adjustability: 12° (21%)

Mass per Pipe Shoe version:

Item no.	Pipe Shoe version	Nominal height	DN (mm)	Mass (kg)
2330922	MP-PS L1-1 21-26 1/2" OC	90	DN15	1.50
2330923	MP-PS L1-1 26-31 3/4" OC	90	DN20	1.52
2330924	MP-PS L1-1 32-37 1" OC	90	DN25	1.54
2330925	MP-PS L1-1 38-44 1-1/4" OC	90	DN32	1.56
2330926	MP-PS L1-1 45-51 1-1/2" OC	90	DN40	1.59
2330927	MP-PS L1-1 52-58 OC	90	OD52-58	1.78
2330928	MP-PS L1-1 59-65 2" OC	90	DN50	1.81
2330929	MP-PS L1-1 68-74 OC	90	OD68-74	1.86
2330930	MP-PS L1-1 75-81 2-1/2" OC	90	DN65	1.89
2330931	MP-PS L1-1 88-94 3" OC	90	DN80	1.95
2330932	MP-PS L1-1 100-108 3-1/2" OC	90	OD100-108	2.01
2330933	MP-PS L1-1 110-118 4" OC	90	DN100	2.04
2330934	MP-PS L1-1 125-133 OC	90	OD125-133	2.13
2330935	MP-PS L1-1 136-144 5" OC	90	DN125	2.18
2330936	MP-PS L1-1 152-162 OC	90	OD152-162	2.27
2330937	MP-PS L1-1 163-173 6" OC	90	DN150	2.33



Corrosion protection:

Component	Coating system	Zinc thickness, min. local (µm)
Top pipe ring	HDG per ISO 1461	55
Bottom pipe ring and midplate	HDG per ISO 1461	70
Baseplate	Continuously hot-dip Zinc-Magnesium coated per EN 10346	17
Serrated washers	Continuously hot-dip Zinc-Magnesium coated per EN 10346	17
Bolts; Nuts	HDG per ISO 10684	40;45

Material properties:

Component/Material	min. Yield strength	min. Ultimate strength	Modulus of elasticity	Shear modulus
Pipe rings and midplate S235JR (DIN EN10025-2)	$f_y = 235 \frac{N}{mm^2}$	$f_u = 360 \frac{N}{mm^2}$	$E = 210000 \frac{N}{mm^2}$	$G = 80769 \frac{N}{mm^2}$
Baseplate and serrated washer S280GD (EN 10346) POSMAC-C MOD	$f_y = 280 \frac{N}{mm^2}$	$f_u = 360 \frac{N}{mm^2}$	$E = 210000 \frac{N}{mm^2}$	$G = 80769 \frac{N}{mm^2}$
Bolts; Nuts F Class 8.8 (ISO 898-1); Grade 8 (ISO 898-2)	$f_y = 640 \frac{N}{mm^2}$	$f_u = 800 \frac{N}{mm^2}$	$E = 210000 \frac{N}{mm^2}$	$G = 80769 \frac{N}{mm^2}$
Sliding plates PA66-GF30	Static friction coefficient values: Hot Dip Galvanized mating surface: 0.13 Zinc-Magnesium mating surface: 0.15 Zinc Electrogalvanised mating surface: 0.18			
Values for Modulus of Elasticity and Shear Modulus are according to EN 1993-1-1 and used for all Eurocode calculations Friction coefficient per ASTM D1894-14				

DESIGN LOADING CAPACITY – 3D

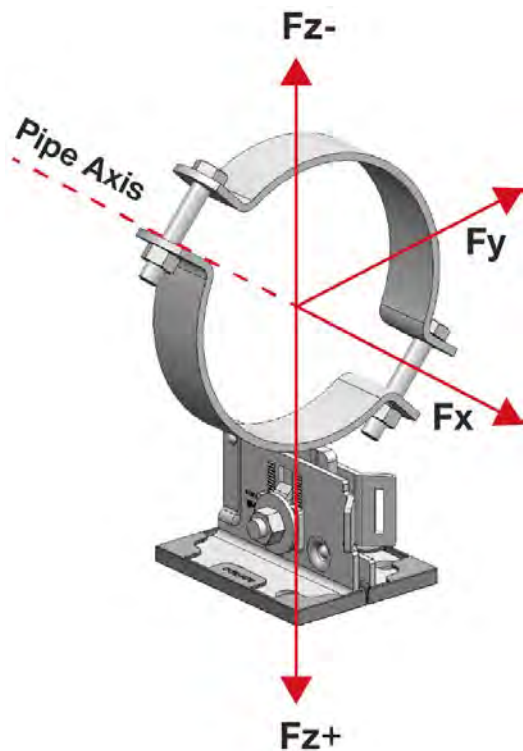
Notes for load data

Load capacity given at delivery height = 90mm BOP (Bottom of pipe).

Point of load application = pipe center line (X-axis).

Load capacity given at room temperature.

Temperature correction factors apply:

- Per VGB-R-510 for load reported acc to

EN13480-3

- Per EN 1993-1-2 for loads reported acc to EN1993-1-1

Temperature distribution on pipe shoe components per EN13480-3

Failure locations per force direction:

Fx – deformation of pipe ring

Fy – deformation of baseplate

+Fz, -Fz – ultimate failure at baseplate serrations

Published loads are based on static loading conditions and mounting according to IFU. Non-static forces must be separately considered during design.

Below published load data is applicable for pipe shoes:

- welded to steel according to IFU
- mounted with MT-TFB OC bolts on MT girders
- mounted with Hex M10 8.8 class bolts on I-beams
- mounted with HST3 Stud Anchors
- mounted with X-BT/ F-BT threaded stud

In case of mounting, following configuration has been considered for load data in combination with the closest holes to the center of gravity:

Pipe shoe configuration	Number of fixation elements, pcs
1-1	2
2-2	4
4-2	8

For all other required loads (i.e. different height, -slope,...) please use Fixpoint Calculator

Recommended loads per EN13480-3

Item No.	Pipe Shoe version	+/-F _{x,rec} [kN]	+/-F _{y,rec} [kN]	+F _{z,rec} [kN]	-F _{z,rec} [kN]
2330922	Pipe shoe MP-PS L1-1 21-26 1/2" OC	1.11	2.51	9.87	7.58
2330923	Pipe shoe MP-PS L1-1 26-31 3/4" OC	1.16	2.44	9.87	7.58
2330924	Pipe shoe MP-PS L1-1 32-37 1" OC	1.22	2.36	9.87	7.58
2330925	Pipe shoe MP-PS L1-1 38-44 1-1/4" OC	1.30	2.27	9.87	7.58
2330926	Pipe shoe MP-PS L1-1 45-51 1-1/2" OC	1.35	2.21	9.87	7.58
2330927	Pipe shoe MP-PS L1-1 52-58 OC	1.40	2.16	9.87	7.58
2330928	Pipe shoe MP-PS L1-1 59-65 2" OC	1.46	2.10	9.87	7.58
2330929	Pipe shoe MP-PS L1-1 68-74 OC	1.54	2.02	9.87	7.58
2330930	Pipe shoe MP-PS L1-1 75-81 2-1/2" OC	1.57	1.97	9.87	7.58
2330931	Pipe shoe MP-PS L1-1 88-94 3" OC	1.71	1.88	9.87	7.58
2330932	Pipe shoe MP-PS L1-1 100-108 3-1/2" OC	1.82	1.79	9.87	7.58
2330933	Pipe shoe MP-PS L1-1 110-118 4" OC	1.93	1.72	9.87	7.58
2330934	Pipe shoe MP-PS L1-1 125-133 OC	2.03	1.66	9.87	7.58
2330935	Pipe shoe MP-PS L1-1 136-144 5" OC	2.17	1.58	9.87	7.58
2330936	Pipe shoe MP-PS L1-1 152-162 OC	2.32	1.49	9.87	7.58
2330937	Pipe shoe MP-PS L1-1 163-173 6" OC	2.41	1.45	9.87	7.58

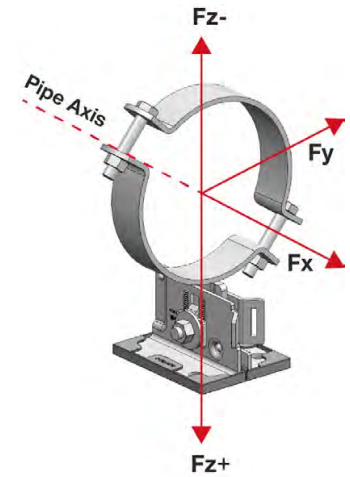
Notes

Shown load data is applicable for pipe shoes without considering the load capacity of the sub-structure and base material.

Interaction formula

$$\left(\frac{F_{x,exp}}{F_{x,rec}}\right)^2 + \left(\frac{F_{y,exp}}{F_{y,rec}}\right)^2 + \left(\frac{F_{z,exp}}{F_{z,rec}}\right)^2 + \frac{F_{x,exp}}{F_{x,rec}} * \frac{F_{y,exp}}{F_{y,rec}} + \frac{F_{x,exp}}{F_{x,rec}} * \frac{F_{z,exp}}{F_{z,rec}} + \frac{F_{y,exp}}{F_{y,rec}} * \frac{F_{z,exp}}{F_{z,rec}} \leq 1.0$$

Recommended loads per EN1993-1-1

Item No.	Pipe Shoe version	+/-F _{x,rec} [kN]	+/-F _{y,rec} [kN]	+/-F _{y,rec} [kN] in combina- tion with X-BT only	+F _{z,rec} [kN]	-F _{z,rec} [kN]	-F _{z,rec} [kN] in combi- nation with X-BT only	-F _{z,rec} [kN] in combi- nation with MT-TFB only	-F _{z,rec} [kN] in combi- nation with HST3 only
2330922	Pipe shoe MP-PS L1-1 21-26 1/2" OC	1.78	3.31	3.24	14.31	10.95	4.94	10.86	8.40
2330923	Pipe shoe MP-PS L1-1 26-31 3/4" OC	1.86	3.22	3.18	14.31	10.95	4.94	10.86	8.40
2330924	Pipe shoe MP-PS L1-1 32-37 1" OC	1.95	3.12	3.10	14.31	10.95	4.94	10.86	8.40
2330925	Pipe shoe MP-PS L1-1 38-44 1-1/4" OC	2.08	2.99	3.00	14.31	10.95	4.94	10.86	8.40
2330926	Pipe shoe MP-PS L1-1 45-51 1-1/2" OC	2.16	2.92	2.92	14.31	10.95	4.94	10.86	8.40
2330927	Pipe shoe MP-PS L1-1 52-58 OC	2.24	2.85	2.85	14.31	10.95	4.94	10.86	8.40
2330928	Pipe shoe MP-PS L1-1 59-65 2" OC	2.33	2.77	2.77	14.31	10.95	4.94	10.86	8.40
2330929	Pipe shoe MP-PS L1-1 68-74 OC	2.47	2.66	2.66	14.31	10.95	4.94	10.86	8.40
2330930	Pipe shoe MP-PS L1-1 75-81 2-1/2" OC	2.51	2.60	2.63	14.31	10.95	4.94	10.86	8.40
2330931	Pipe shoe MP-PS L1-1 88-94 3" OC	2.73	2.48	2.48	14.31	10.95	4.94	10.86	8.40
2330932	Pipe shoe MP-PS L1-1 100-108 3-1/2" OC	2.91	2.36	2.36	14.31	10.95	4.94	10.86	8.40
2330933	Pipe shoe MP-PS L1-1 110-118 4" OC	3.09	2.26	2.26	14.31	10.95	4.94	10.86	8.40
2330934	Pipe shoe MP-PS L1-1 125-133 OC	3.24	2.18	2.18	14.31	10.95	4.94	10.86	8.40
2330935	Pipe shoe MP-PS L1-1 136-144 5" OC	3.47	2.08	2.07	14.31	10.95	4.94	10.86	8.40
2330936	Pipe shoe MP-PS L1-1 152-162 OC	3.72	1.96	1.96	14.31	10.95	4.94	10.86	8.40
2330937	Pipe shoe MP-PS L1-1 163-173 6" OC	3.85	1.91	1.91	14.31	10.95	4.94	10.86	8.40

Notes

Shown EN1993-1-1 load values are recommended values with partial safety factors for action and resistance included. Design value in X & Y directions = 1.0 x recommended value. Design value in Z direction = 1.35 x recommended value.

MT-TFB OC and Hex M10 8.8 bolts: partial safety factors on reaction side of 1.0 in X and Y directions and 1.35 in Z direction

HST3: no edge distance and spacing influence, minimum base material thickness considered, cracked concrete C 20/25, f_{ck,cube}=25 N/mm², partial safety factors on reaction side of 1.0 in X and Y directions and 1.35 in Z direction.

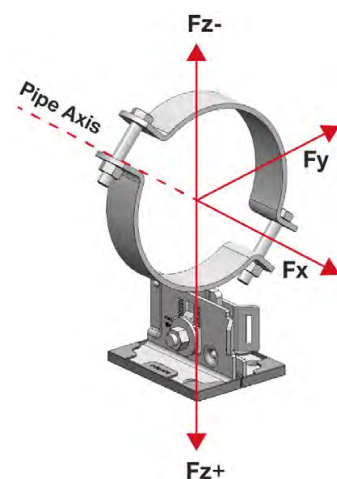
Interaction formula

$$\frac{F_{x,exp}}{F_{x,rec}} + \frac{F_{y,exp}}{F_{y,rec}} + \frac{F_{z,exp}}{F_{z,rec}} \leq 1.0$$

PIPE SHOE MP-PS M1-1

General

Media temperature limits: -20 °C to +300 °C

Height adjustability: 116 - 171 mm (with sliding plate)
113 - 168 mm (without sliding plate)

Slope adjustability: 12° (21%)

Mass per Pipe Shoe version:

Item no.	Pipe Shoe version	Nominal height	DN (mm)	Mass (kg)
2330938	Pipe shoe MP-PS M1-1 21-26 1/2" OC	150	DN15	1.78
2330939	Pipe shoe MP-PS M1-1 26-31 3/4" OC	150	DN20	1.80
2330940	Pipe shoe MP-PS M1-1 32-37 1" OC	150	DN25	1.82
2330941	Pipe shoe MP-PS M1-1 38-44 1-1/4" OC	150	DN32	1.84
2330942	Pipe shoe MP-PS M1-1 45-51 1-1/2" OC	150	DN40	1.87
2330943	Pipe shoe MP-PS M1-1 52-58 OC	150	OD52-58	2.06
2330944	Pipe shoe MP-PS M1-1 59-65 2" OC	150	DN50	2.09
2330945	Pipe shoe MP-PS M1-1 68-74 OC	150	OD68-74	2.14
2330946	Pipe shoe MP-PS M1-1 75-81 2-1/2" OC	150	DN65	2.17
2330947	Pipe shoe MP-PS M1-1 88-94 3" OC	150	DN80	2.23
2330948	Pipe shoe MP-PS M1-1 100-108 3-1/2" OC	150	OD100-108	2.29
2330949	Pipe shoe MP-PS M1-1 110-118 4" OC	150	DN100	2.32
2330950	Pipe shoe MP-PS M1-1 125-133 OC	150	OD125-133	2.41
2330951	Pipe shoe MP-PS M1-1 136-144 5" OC	150	DN125	2.46
2330952	Pipe shoe MP-PS M1-1 152-162 OC	150	OD152-162	2.55
2330953	Pipe shoe MP-PS M1-1 163-173 6" OC	150	DN150	2.61



Corrosion protection:

Component	Coating system	Zinc thickness, min. local (µm)
Top pipe ring	HDG per ISO 1461	55
Bottom pipe ring and midplate	HDG per ISO 1461	70
Baseplate	Continuously hot-dip Zinc-Magnesium coated per EN 10346	17
Serrated washers	Continuously hot-dip Zinc-Magnesium coated per EN 10346	17
Bolts; Nuts	HDG per ISO 10684	40;45

Material properties:

Component/Material	min. Yield strength	min. Ultimate strength	Modulus of elasticity	Shear modulus
Pipe rings and midplate S235JR (DIN EN10025-2)	$f_y = 235 \frac{N}{mm^2}$	$f_u = 360 \frac{N}{mm^2}$	$E = 210000 \frac{N}{mm^2}$	$G = 80769 \frac{N}{mm^2}$
Baseplate and serrated washer S280GD (EN 10346) POSMAC-C MOD	$f_y = 280 \frac{N}{mm^2}$	$f_u = 360 \frac{N}{mm^2}$	$E = 210000 \frac{N}{mm^2}$	$G = 80769 \frac{N}{mm^2}$
Bolts; Nuts F Class 8.8 (ISO 898-1); Grade 8 (ISO 898-2)	$f_y = 640 \frac{N}{mm^2}$	$f_u = 800 \frac{N}{mm^2}$	$E = 210000 \frac{N}{mm^2}$	$G = 80769 \frac{N}{mm^2}$
Sliding plates PA66-GF30	Static friction coefficient values: Hot Dip Galvanized mating surface: 0.13 Zinc-Magnesium mating surface: 0.15 Zinc Electrogalvanised mating surface: 0.18			
Values for Modulus of Elasticity and Shear Modulus are according to EN 1993-1-1 and used for all Eurocode calculations Friction coefficient per ASTM D1894-14				

DESIGN LOADING CAPACITY – 3D

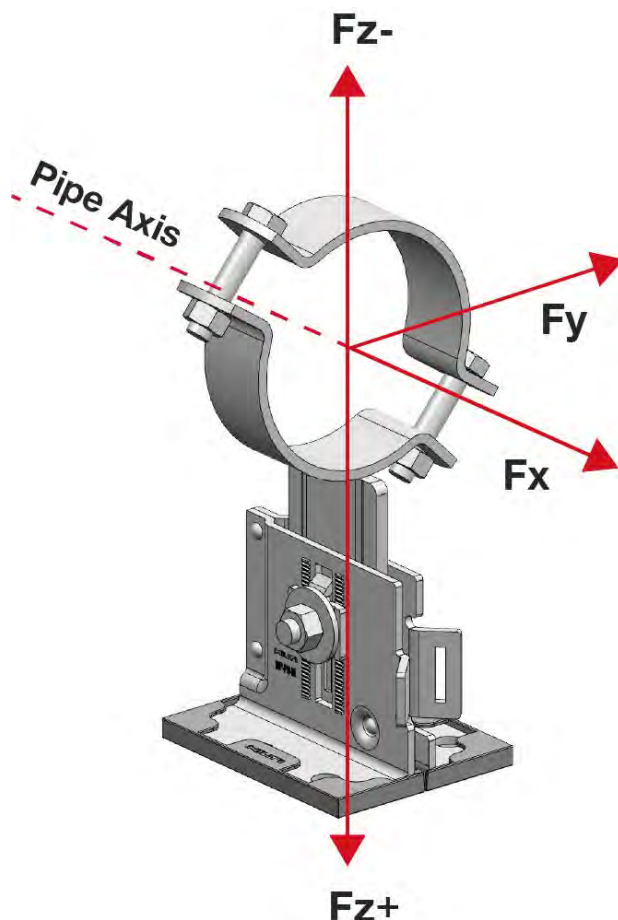
Notes for load data

Load capacity given at delivery height = 150mm BOP (Bottom of pipe).

Point of load application = pipe center line (X-axis).

Load capacity given at room temperature.

Temperature correction factors apply:

- Per VGB-R-510 for load reported acc to EN13480-3

- Per EN 1993-1-2 for loads reported acc to EN1993-1-1

Temperature distribution on pipe shoe components per EN13480-3

Failure locations per force direction:

F_x – deformation of pipe ring

F_y – deformation of baseplate

+ F_z , - F_z – ultimate failure at baseplate serrations

Published loads are based on static loading conditions and mounting according to IFU. Non-static forces must be separately considered during design.

Below published load data is applicable for pipe shoes:

- welded to steel according to IFU
- mounted with MT-TFB OC bolts on MT girders
- mounted with Hex M10 8.8 class bolts on I-beams
- mounted with HST3 Stud Anchors
- mounted with X-BT/ F-BT threaded stud

In case of mounting, following configuration has been considered for load data in combination with the closest holes to the center of gravity:

Pipe shoe configuration	Number of fixation elements, pcs
1-1	2
2-2	4
4-2	8

For all other required loads (i.e. different height, -slope,...) please use Fixpoint Calculator

Recommended loads per EN13480-3

Item no.	Pipe Shoe version	+/-F _{x,rec} [kN]	+/-F _{y,rec} [kN]	+F _{z,rec} [kN]	-F _{z,rec} [kN]
2330938	Pipe shoe MP-PS M1-1 21-26 1/2" OC	1.11	1.57	9.87	7.58
2330939	Pipe shoe MP-PS M1-1 26-31 3/4" OC	1.16	1.54	9.87	7.58
2330940	Pipe shoe MP-PS M1-1 32-37 1" OC	1.22	1.51	9.87	7.58
2330941	Pipe shoe MP-PS M1-1 38-44 1-1/4" OC	1.30	1.47	9.87	7.58
2330942	Pipe shoe MP-PS M1-1 45-51 1-1/2" OC	1.35	1.45	9.87	7.58
2330943	Pipe shoe MP-PS M1-1 52-58 OC	1.40	1.43	9.87	7.58
2330944	Pipe shoe MP-PS M1-1 59-65 2" OC	1.46	1.40	9.87	7.58
2330945	Pipe shoe MP-PS M1-1 68-74 OC	1.54	1.36	9.87	7.58
2330946	Pipe shoe MP-PS M1-1 75-81 2-1/2" OC	1.57	1.34	9.87	7.58
2330947	Pipe shoe MP-PS M1-1 88-94 3" OC	1.71	1.30	9.87	7.58
2330948	Pipe shoe MP-PS M1-1 100-108 3-1/2" OC	1.82	1.26	9.87	7.58
2330949	Pipe shoe MP-PS M1-1 110-118 4" OC	1.93	1.22	9.87	7.58
2330950	Pipe shoe MP-PS M1-1 125-133 OC	2.03	1.19	9.87	7.58
2330951	Pipe shoe MP-PS M1-1 136-144 5" OC	2.17	1.15	9.87	7.58
2330952	Pipe shoe MP-PS M1-1 152-162 OC	2.32	1.10	9.87	7.58
2330953	Pipe shoe MP-PS M1-1 163-173 6" OC	2.41	1.08	9.87	7.58

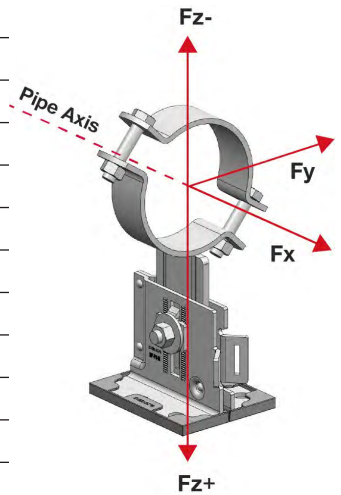
Notes

Shown load data is applicable for pipe shoes without considering the load capacity of the sub-structure and base material.

Interaction formula

$$\left(\frac{F_{x,exp}}{F_{x,rec}}\right)^2 + \left(\frac{F_{y,exp}}{F_{y,rec}}\right)^2 + \left(\frac{F_{z,exp}}{F_{z,rec}}\right)^2 + \frac{F_{x,exp}}{F_{x,rec}} * \frac{F_{y,exp}}{F_{y,rec}} + \frac{F_{x,exp}}{F_{x,rec}} * \frac{F_{z,exp}}{F_{z,rec}} + \frac{F_{y,exp}}{F_{y,rec}} * \frac{F_{z,exp}}{F_{z,rec}} \leq 1.0$$

Recommended loads per EN1993-1-1

Item no.	Pipe Shoe version	+/-F _{x,rec} [kN]	+/-F _{y,rec} [kN]	+F _{z,rec} [kN]	-F _{z,rec} [kN]	-F _{z,rec} [kN] in combi- nation with X-BT only	-F _{z,rec} [kN] in com- bina- tion with MT-TFB only	-F _{z,rec} [kN] in com- bina- tion with HST3 only
2330938	Pipe shoe MP-PS M1-1 21-26 1/2" OC	1.78	2.07	14.31	10.95	4.94	10.86	8.40
2330939	Pipe shoe MP-PS M1-1 26-31 3/4" OC	1.86	2.04	14.31	10.95	4.94	10.86	8.40
2330940	Pipe shoe MP-PS M1-1 32-37 1" OC	1.95	2.00	14.31	10.95	4.94	10.86	8.40
2330941	Pipe shoe MP-PS M1-1 38-44 1-1/4" OC	2.08	1.94	14.31	10.95	4.94	10.86	8.40
2330942	Pipe shoe MP-PS M1-1 45-51 1-1/2" OC	2.16	1.91	14.31	10.95	4.94	10.86	8.40
2330943	Pipe shoe MP-PS M1-1 52-58 OC	2.24	1.88	14.31	10.95	4.94	10.86	8.40
2330944	Pipe shoe MP-PS M1-1 59-65 2" OC	2.33	1.85	14.31	10.95	4.94	10.86	8.40
2330945	Pipe shoe MP-PS M1-1 68-74 OC	2.47	1.80	14.31	10.95	4.94	10.86	8.40
2330946	Pipe shoe MP-PS M1-1 75-81 2-1/2" OC	2.51	1.77	14.31	10.95	4.94	10.86	8.40
2330947	Pipe shoe MP-PS M1-1 88-94 3" OC	2.73	1.71	14.31	10.95	4.94	10.86	8.40
2330948	Pipe shoe MP-PS M1-1 100-108 3-1/2" OC	2.91	1.66	14.31	10.95	4.94	10.86	8.40
2330949	Pipe shoe MP-PS M1-1 110-118 4" OC	3.09	1.61	14.31	10.95	4.94	10.86	8.40
2330950	Pipe shoe MP-PS M1-1 125-133 OC	3.24	1.57	14.31	10.95	4.94	10.86	8.40
2330951	Pipe shoe MP-PS M1-1 136-144 5" OC	3.47	1.51	14.31	10.95	4.94	10.86	8.40
2330952	Pipe shoe MP-PS M1-1 152-162 OC	3.72	1.45	14.31	10.95	4.94	10.86	8.40
2330953	Pipe shoe MP-PS M1-1 163-173 6" OC	3.85	1.42	14.31	10.95	4.94	10.86	8.40

Notes

Shown EN1993-1-1 load values are recommended values with partial safety factors for action and resistance included. Design value in X & Y directions = 1.0 x recommended value. Design value in Z direction = 1.35 x recommended value.

MT-TFB OC and Hex M10 8.8 bolts: partial safety factors on reaction side of 1.0 in X and Y directions and 1.35 in Z direction

HST3: no edge distance and spacing influence, minimum base material thickness considered, cracked concrete C 20/25, f_{ck,cube}=25 N/mm², partial safety factors on reaction side of 1.0 in X and Y directions and 1.35 in Z direction.

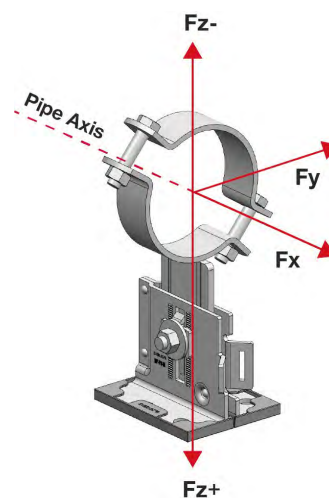
Interaction formula

$$\frac{F_{x,exp}}{F_{x,rec}} + \frac{F_{y,exp}}{F_{y,rec}} + \frac{F_{z,exp}}{F_{z,rec}} \leq 1.0$$

PIPE SHOE MP-PS H1-1

General

Media temperature limits: -20 °C to +300 °C

Height adjustability: 171 - 223.5 mm (with sliding plate)
168 - 220.5 mm (without sliding plate)

Slope adjustability: 12° (21%)

Mass per Pipe Shoe version:

Item no.	Pipe Shoe version	Nominal height	DN (mm)	Mass (kg)
2330954	Pipe shoe MP-PS H1-1 21-26 1/2" OC	200	DN15	2.19
2330955	Pipe shoe MP-PS H1-1 26-31 3/4" OC	200	DN20	2.20
2330956	Pipe shoe MP-PS H1-1 32-37 1" OC	200	DN25	2.23
2330957	Pipe shoe MP-PS H1-1 38-44 1-1/4" OC	200	DN32	2.25
2330958	Pipe shoe MP-PS H1-1 45-51 1-1/2" OC	200	DN40	2.27
2330959	Pipe shoe MP-PS H1-1 52-58 OC	200	OD52-58	2.46
2330960	Pipe shoe MP-PS H1-1 59-65 2" OC	200	DN50	2.50
2330961	Pipe shoe MP-PS H1-1 68-74 OC	200	OD68-74	2.54
2330962	Pipe shoe MP-PS H1-1 75-81 2-1/2" OC	200	DN65	2.58
2330963	Pipe shoe MP-PS H1-1 88-94 3" OC	200	DN80	2.64
2330964	Pipe shoe MP-PS H1-1 100-108 3-1/2" OC	200	OD100-108	2.69
2330965	Pipe shoe MP-PS H1-1 110-118 4" OC	200	DN100	2.73
2330966	Pipe shoe MP-PS H1-1 125-133 OC	200	OD125-133	2.81
2330967	Pipe shoe MP-PS H1-1 136-144 5" OC	200	DN125	2.87
2330968	Pipe shoe MP-PS H1-1 152-162 OC	200	OD152-162	2.96
2330969	Pipe shoe MP-PS H1-1 163-173 6" OC	200	DN150	3.01



Corrosion protection:

Component	Coating system	Zinc thickness, min. local (µm)
Top pipe ring	HDG per ISO 1461	55
Bottom pipe ring and midplate	HDG per ISO 1461	70
Baseplate	Continuously hot-dip Zinc-Magnesium coated per EN 10346	17
Serrated washers	Continuously hot-dip Zinc-Magnesium coated per EN 10346	17
Bolts; Nuts	HDG per ISO 10684	40;45

Material properties:

Component/Material	min. Yield strength	min. Ultimate strength	Modulus of elasticity	Shear modulus
Pipe rings and midplate S235JR (DIN EN10025-2)	$f_y = 235 \frac{N}{mm^2}$	$f_u = 360 \frac{N}{mm^2}$	$E = 210000 \frac{N}{mm^2}$	$G = 80769 \frac{N}{mm^2}$
Baseplate and serrated washer S280GD (EN 10346) POSMAC-C MOD	$f_y = 280 \frac{N}{mm^2}$	$f_u = 360 \frac{N}{mm^2}$	$E = 210000 \frac{N}{mm^2}$	$G = 80769 \frac{N}{mm^2}$
Bolts; Nuts F Class 8.8 (ISO 898-1); Grade 8 (ISO 898-2)	$f_y = 640 \frac{N}{mm^2}$	$f_u = 800 \frac{N}{mm^2}$	$E = 210000 \frac{N}{mm^2}$	$G = 80769 \frac{N}{mm^2}$
Sliding plates PA66-GF30	Static friction coefficient values: Hot Dip Galvanized mating surface: 0.13 Zinc-Magnesium mating surface: 0.15 Zinc Electrogalvanised mating surface: 0.18			
Values for Modulus of Elasticity and Shear Modulus are according to EN 1993-1-1 and used for all Eurocode calculations Friction coefficient per ASTM D1894-14				

DESIGN LOADING CAPACITY – 3D

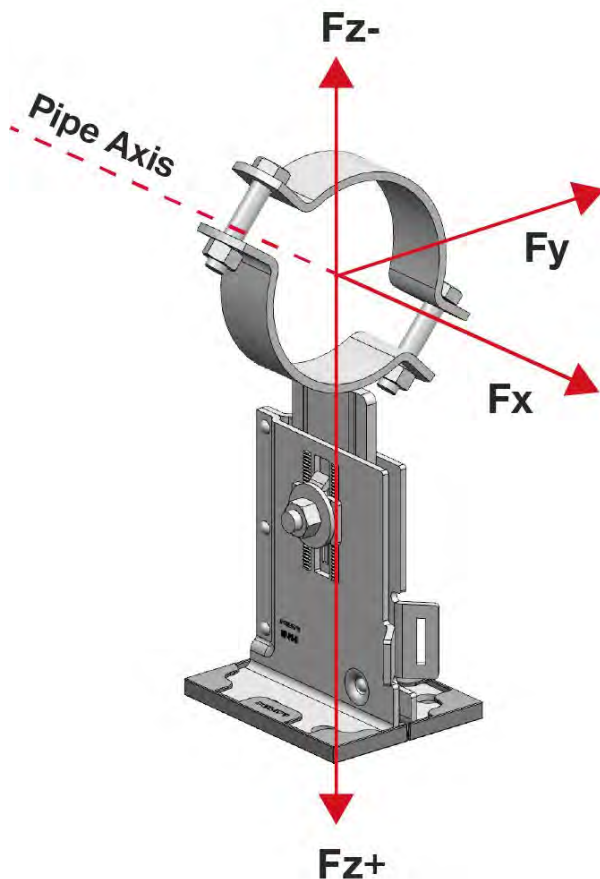
Notes for load data

Load capacity given at delivery height = 200mm BOP (Bottom of pipe).

Point of load application = pipe center line (X-axis).

Load capacity given at room temperature.

Temperature correction factors apply:

- Per VGB-R-510 for load reported acc to EN13480-3

- Per EN 1993-1-2 for loads reported acc to EN1993-1-1

Temperature distribution on pipe shoe components per EN13480-3

Failure locations per force direction:

F_x – deformation of pipe ring

F_y – deformation of baseplate

+F_z, -F_z – ultimate failure at baseplate serrations

Published loads are based on static loading conditions and mounting according to IFU. Non-static forces must be separately considered during design.

Below published load data is applicable for pipe shoes:

- welded to steel according to IFU
- mounted with MT-TFB OC bolts on MT girders
- mounted with Hex M10 8.8 class bolts on I-beams
- mounted with HST3 Stud Anchors
- mounted with X-BT/ F-BT threaded stud

In case of mounting, following configuration has been considered for load data in combination with the closest holes to the center of gravity:

Pipe shoe configuration	Number of fixation elements, pcs
1-1	2
2-2	4
4-2	8

For all other required loads (i.e. different height, -slope,...) please use Fixpoint Calculator

Recommended loads per EN13480-3

Item no.	Pipe Shoe version	+/-F _{x,rec} [kN]	+/-F _{y,rec} [kN]	+F _{z,rec} [kN]	-F _{z,rec} [kN]
2330954	Pipe shoe MP-PS H1-1 21-26 1/2" OC	1.11	1.20	9.87	7.58
2330955	Pipe shoe MP-PS H1-1 26-31 3/4" OC	1.16	1.18	9.87	7.58
2330956	Pipe shoe MP-PS H1-1 32-37 1" OC	1.22	1.16	9.87	7.58
2330957	Pipe shoe MP-PS H1-1 38-44 1-1/4" OC	1.30	1.14	9.87	7.58
2330958	Pipe shoe MP-PS H1-1 45-51 1-1/2" OC	1.35	1.13	9.87	7.58
2330959	Pipe shoe MP-PS H1-1 52-58 OC	1.40	1.11	9.87	7.58
2330960	Pipe shoe MP-PS H1-1 59-65 2" OC	1.46	1.10	9.87	7.58
2330961	Pipe shoe MP-PS H1-1 68-74 OC	1.54	1.07	9.87	7.58
2330962	Pipe shoe MP-PS H1-1 75-81 2-1/2" OC	1.57	1.06	9.87	7.58
2330963	Pipe shoe MP-PS H1-1 88-94 3" OC	1.71	1.03	9.87	7.58
2330964	Pipe shoe MP-PS H1-1 100-108 3-1/2" OC	1.82	1.01	9.87	7.58
2330965	Pipe shoe MP-PS H1-1 110-118 4" OC	1.93	0.98	9.87	7.58
2330966	Pipe shoe MP-PS H1-1 125-133 OC	2.03	0.96	9.87	7.58
2330967	Pipe shoe MP-PS H1-1 136-144 5" OC	2.17	0.94	9.87	7.58
2330968	Pipe shoe MP-PS H1-1 152-162 OC	2.32	0.90	9.87	7.58
2330969	Pipe shoe MP-PS H1-1 163-173 6" OC	2.41	0.89	9.87	7.58

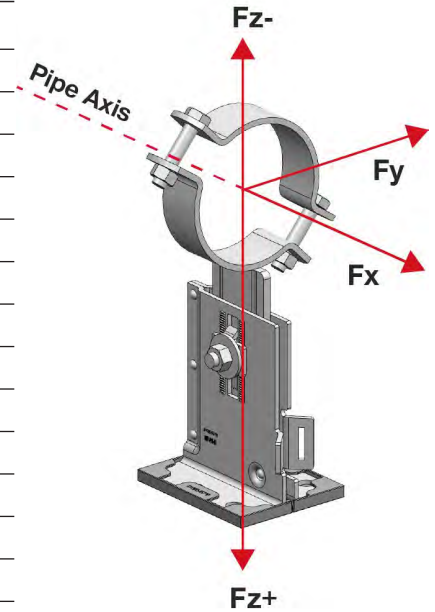
Notes

Shown load data is applicable for pipe shoes without considering the load capacity of the sub-structure and base material.

Interaction formula

$$\left(\frac{F_{x,exp}}{F_{x,rec}}\right)^2 + \left(\frac{F_{y,exp}}{F_{y,rec}}\right)^2 + \left(\frac{F_{z,exp}}{F_{z,rec}}\right)^2 + \frac{F_{x,exp}}{F_{x,rec}} * \frac{F_{y,exp}}{F_{y,rec}} + \frac{F_{x,exp}}{F_{x,rec}} * \frac{F_{z,exp}}{F_{z,rec}} + \frac{F_{y,exp}}{F_{y,rec}} * \frac{F_{z,exp}}{F_{z,rec}} \leq 1.0$$

Recommended loads per EN1993-1-1

Item no.	Pipe Shoe version	+/-F _{x,rec} [kN]	+/-F _{y,rec} [kN]	+F _{z,rec} [kN]	-F _{z,rec} [kN]	-F _{z,rec} [kN] in combi- nation with X-BT only	-F _{z,rec} [kN] in combi- nation with MT-TFB only	-F _{z,rec} [kN] in combi- nation with HST3 only
2330954	Pipe shoe MP-PS H1-1 21-26 1/2" OC	1.78	1.58	14.31	10.95	4.94	10.86	8.40
2330955	Pipe shoe MP-PS H1-1 26-31 3/4" OC	1.86	1.56	14.31	10.95	4.94	10.86	8.40
2330956	Pipe shoe MP-PS H1-1 32-37 1" OC	1.95	1.54	14.31	10.95	4.94	10.86	8.40
2330957	Pipe shoe MP-PS H1-1 38-44 1-1/4" OC	2.08	1.50	14.31	10.95	4.94	10.86	8.40
2330958	Pipe shoe MP-PS H1-1 45-51 1-1/2" OC	2.16	1.49	14.31	10.95	4.94	10.86	8.40
2330959	Pipe shoe MP-PS H1-1 52-58 OC	2.24	1.47	14.31	10.95	4.94	10.86	8.40
2330960	Pipe shoe MP-PS H1-1 59-65 2" OC	2.33	1.45	14.31	10.95	4.94	10.86	8.40
2330961	Pipe shoe MP-PS H1-1 68-74 OC	2.47	1.42	14.31	10.95	4.94	10.86	8.40
2330962	Pipe shoe MP-PS H1-1 75-81 2-1/2" OC	2.51	1.40	14.31	10.95	4.94	10.86	8.40
2330963	Pipe shoe MP-PS H1-1 88-94 3" OC	2.73	1.36	14.31	10.95	4.94	10.86	8.40
2330964	Pipe shoe MP-PS H1-1 100-108 3-1/2" OC	2.91	1.33	14.31	10.95	4.94	10.86	8.40
2330965	Pipe shoe MP-PS H1-1 110-118 4" OC	3.09	1.29	14.31	10.95	4.94	10.86	8.40
2330966	Pipe shoe MP-PS H1-1 125-133 OC	3.24	1.27	14.31	10.95	4.94	10.86	8.40
2330967	Pipe shoe MP-PS H1-1 136-144 5" OC	3.47	1.23	14.31	10.95	4.94	10.86	8.40
2330968	Pipe shoe MP-PS H1-1 152-162 OC	3.72	1.19	14.31	10.95	4.94	10.86	8.40
2330969	Pipe shoe MP-PS H1-1 163-173 6" OC	3.85	1.17	14.31	10.95	4.94	10.86	8.40

Notes

Shown EN1993-1-1 load values are recommended values with partial safety factors for action and resistance included. Design value in X & Y directions = 1.0 x recommended value. Design value in Z direction = 1.35 x recommended value.

MT-TFB OC and Hex M10 8.8 bolts: partial safety factors on reaction side of 1.0 in X and Y directions and 1.35 in Z direction

HST3: no edge distance and spacing influence, minimum base material thickness considered, cracked concrete C 20/25, f_{ck,cube}=25 N/mm², partial safety factors on reaction side of 1.0 in X and Y directions and 1.35 in Z direction.

Interaction formula

$$\frac{F_{x,exp}}{F_{x,rec}} + \frac{F_{y,exp}}{F_{y,rec}} + \frac{F_{z,exp}}{F_{z,rec}} \leq 1.0$$

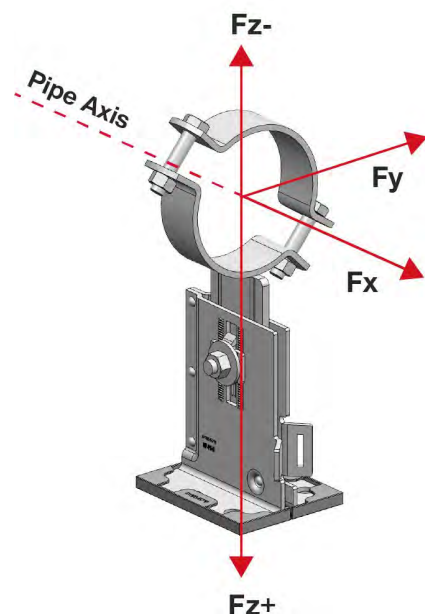

PIPE SHOE MP-PS L2-2

General

Media temperature limits: -20 °C to +300 °C

Height adjustability: 88.5 - 116 mm (with sliding plate)
85.5 - 113 mm (without sliding plate)

Slope adjustability: 12° (21%)

Mass per Pipe Shoe version:

Item no.	Pipe Shoe version	Nominal height	DN (mm)	Mass (kg)
2330973	MP-PS L2-2 21-26 1/2" OC	90	DN15	3.12
2330974	MP-PS L2-2 26-31 3/4" OC	90	DN20	3.15
2330975	MP-PS L2-2 32-37 1" OC	90	DN25	3.20
2330976	MP-PS L2-2 38-44 1-1/4" OC	90	DN32	3.24
2330977	MP-PS L2-2 45-51 1-1/2" OC	90	DN40	3.29
2330978	MP-PS L2-2 52-58 OC	90	OD52-58	3.67
2330979	MP-PS L2-2 59-65 2" OC	90	DN50	3.74
2330980	MP-PS L2-2 68-74 OC	90	OD68-74	3.83
2330981	MP-PS L2-2 75-81 2-1/2" OC	90	DN65	3.90
2330982	MP-PS L2-2 88-94 3" OC	90	DN80	4.02
2330983	MP-PS L2-2 100-108 3-1/2" OC	90	OD100-108	4.13
2330984	MP-PS L2-2 110-118 4" OC	90	DN100	4.22
2330985	MP-PS L2-2 125-133 OC	90	OD125-133	4.37
2330986	MP-PS L2-2 136-144 5" OC	90	DN125	4.48
2330987	MP-PS L2-2 152-162 OC	90	OD152-162	4.66
2330988	MP-PS L2-2 163-173 6" OC	90	DN150	4.77
2330989	MP-PS L2-2 192-202 7" OC	90	OD192-202	6.11
2330990	MP-PS L2-2 217-227 8" OC	90	DN200	6.48
2330991	MP-PS L2-2 244-254 OC	90	OD244-254	7.35
2330992	MP-PS L2-2 267-277 10" OC	90	DN250	7.68
2330993	MP-PS L2-2 318-328 12" OC	90	DN300	8.43

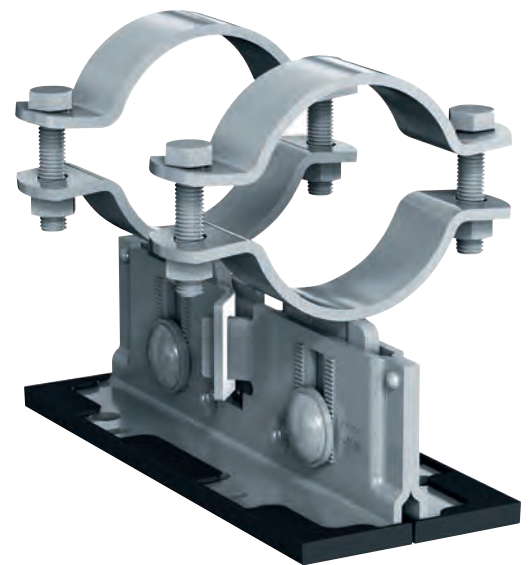

Corrosion protection:

Component	Coating system	Zinc thickness, min. local (µm)
Top pipe ring	HDG per ISO 1461	55
Bottom pipe ring and midplate	HDG per ISO 1461	70
Baseplate	Continuously hot-dip Zinc-Magnesium coated per EN 10346	17
Serrated washers	Continuously hot-dip Zinc-Magnesium coated per EN 10346	17
Bolts; Nuts	HDG per ISO 10684	40;45

Material properties:

Component/Material	min. Yield strength	min. Ultimate strength	Modulus of elasticity	Shear modulus
Pipe rings and midplate S235JR (DIN EN10025-2)	$f_y = 235 \frac{N}{mm^2}$	$f_u = 360 \frac{N}{mm^2}$	$E = 210000 \frac{N}{mm^2}$	$G = 80769 \frac{N}{mm^2}$
Baseplate and serrated washer S280GD (EN 10346) POSMAC-C MOD	$f_y = 280 \frac{N}{mm^2}$	$f_u = 360 \frac{N}{mm^2}$	$E = 210000 \frac{N}{mm^2}$	$G = 80769 \frac{N}{mm^2}$
Bolts; Nuts F Class 8.8 (ISO 898-1); Grade 8 (ISO 898-2)	$f_y = 640 \frac{N}{mm^2}$	$f_u = 800 \frac{N}{mm^2}$	$E = 210000 \frac{N}{mm^2}$	$G = 80769 \frac{N}{mm^2}$
Sliding plates PA66-GF30	Static friction coefficient values: Hot Dip Galvanized mating surface: 0.13 Zinc-Magnesium mating surface: 0.15 Zinc Electrogalvanised mating surface: 0.18			
Values for Modulus of Elasticity and Shear Modulus are according to EN 1993-1-1 and used for all Eurocode calculations Friction coefficient per ASTM D1894-14				

DESIGN LOADING CAPACITY – 3D

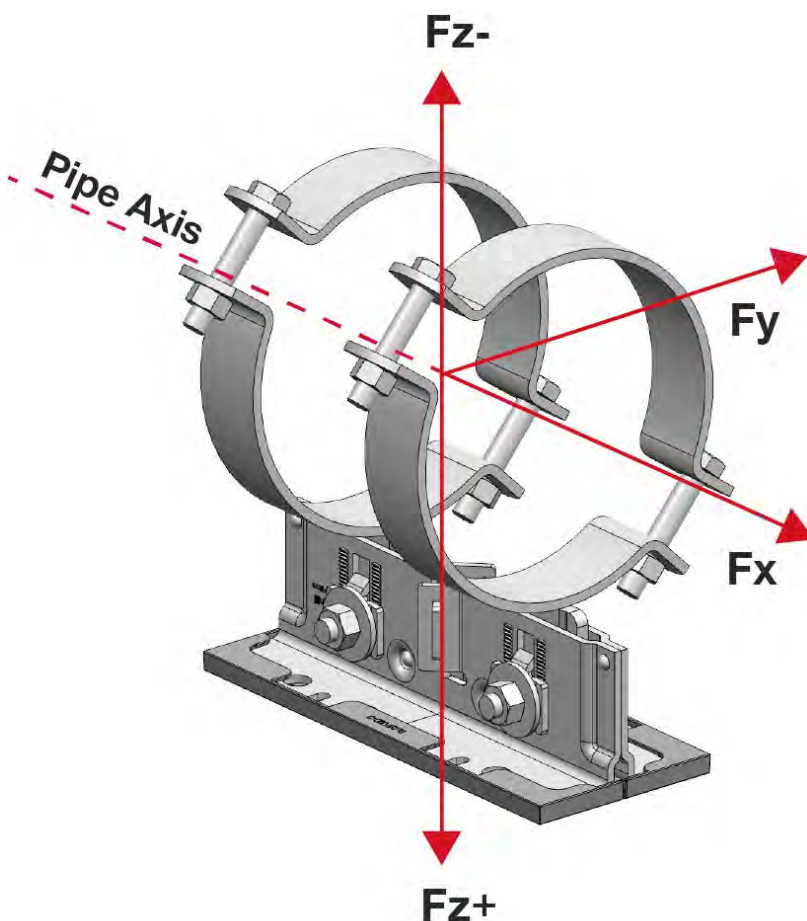
Notes for load data

Load capacity given at delivery height = 90mm BOP (Bottom of pipe).

Point of load application = pipe center line (X-axis).

Load capacity given at room temperature.

Temperature correction factors apply:

- Per VGB-R-510 for load reported acc to EN13480-3
 - Per EN 1993-1-2 for loads reported acc to EN1993-1-1
- Temperature distribution on pipe shoe components per EN13480-3

Failure locations per force direction:

F_x – deformation of pipe ring

F_y – deformation of baseplate

+F_z, -F_z – ultimate failure at baseplate serrations

Published loads are based on static loading conditions and mounting according to IFU. Non-static forces must be separately considered during design.

Below published load data is applicable for pipe shoes:

- welded to steel according to IFU
- mounted with MT-TFB OC bolts on MT girders
- mounted with Hex M10 8.8 class bolts on I-beams
- mounted with HST3 Stud Anchors
- mounted with X-BT/ F-BT threaded stud

In case of mounting, following configuration has been considered for load data in combination with the closest holes to the center of gravity:

Pipe shoe configuration	Number of fixation elements, pcs
1-1	2
2-2	4
4-2	8

For all other required loads (i.e. different height, -slope,...) please use Fixpoint Calculator

Recommended loads per EN13480-3

Item No.	Pipe Shoe version	+/-F _{x,rec} [kN]	+/-F _{y,rec} [kN]	+F _{z,rec} [kN]	-F _{z,rec} [kN]
2330973	Pipe shoe MP-PS L2-2 21-26 1/2" OC	11.29	3.85	17.57	13.44
2330974	Pipe shoe MP-PS L2-2 26-31 3/4" OC	11.42	3.75	17.57	13.44
2330975	Pipe shoe MP-PS L2-2 32-37 1" OC	11.58	3.63	17.57	13.44
2330976	Pipe shoe MP-PS L2-2 38-44 1-1/4" OC	11.79	3.49	17.57	13.44
2330977	Pipe shoe MP-PS L2-2 45-51 1-1/2" OC	11.94	3.40	17.57	13.44
2330978	Pipe shoe MP-PS L2-2 52-58 OC	12.08	3.31	17.57	13.44
2330979	Pipe shoe MP-PS L2-2 59-65 2" OC	12.23	3.23	17.57	13.44
2330980	Pipe shoe MP-PS L2-2 68-74 OC	12.47	3.10	17.57	13.44
2330981	Pipe shoe MP-PS L2-2 75-81 2-1/2" OC	12.54	3.03	17.57	13.44
2330982	Pipe shoe MP-PS L2-2 88-94 3" OC	12.93	2.88	17.57	13.44
2330983	Pipe shoe MP-PS L2-2 100-108 3-1/2" OC	13.23	2.75	17.57	13.44
2330984	Pipe shoe MP-PS L2-2 110-118 4" OC	13.54	2.63	17.57	13.44
2330985	Pipe shoe MP-PS L2-2 125-133 OC	13.80	2.54	17.57	13.44
2330986	Pipe shoe MP-PS L2-2 136-144 5" OC	14.20	2.42	17.57	13.44
2330987	Pipe shoe MP-PS L2-2 152-162 OC	14.63	2.29	17.57	13.44
2330988	Pipe shoe MP-PS L2-2 163-173 6" OC	14.85	2.23	17.57	13.44
2330989	Pipe shoe MP-PS L2-2 192-202 7" OC	15.47	2.07	17.57	13.44
2330990	Pipe shoe MP-PS L2-2 217-227 8" OC	16.09	1.94	17.57	13.44
2330991	Pipe shoe MP-PS L2-2 244-254 OC	16.84	1.80	17.57	13.44
2330992	Pipe shoe MP-PS L2-2 267-277 10" OC	17.40	1.71	17.57	13.44
2330993	Pipe shoe MP-PS L2-2 318-328 12" OC	18.58	1.54	17.57	13.44

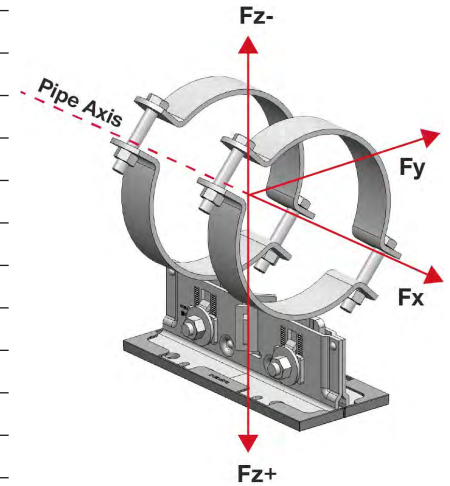
Notes

Shown load data is applicable for pipe shoes without considering the load capacity of the sub-structure and base material.

Interaction formula

$$\left(\frac{F_{x,exp}}{F_{x,rec}}\right)^2 + \left(\frac{F_{y,exp}}{F_{y,rec}}\right)^2 + \left(\frac{F_{z,exp}}{F_{z,rec}}\right)^2 + \frac{F_{x,exp}}{F_{x,rec}} * \frac{F_{y,exp}}{F_{y,rec}} + \frac{F_{x,exp}}{F_{x,rec}} * \frac{F_{z,exp}}{F_{z,rec}} + \frac{F_{y,exp}}{F_{y,rec}} * \frac{F_{z,exp}}{F_{z,rec}} \leq 1.0$$

Recommended loads per EN1993-1-1

Item No.	Pipe Shoe version	+/-F _{x,rec} [kN]	+/-F _{x,rec} [kN] in combina- tion with X-BT only	+/-F _{x,rec} [kN] in combi- nation with F-BT only	+/-F _{y,rec} [kN]	+F _{z,rec} [kN]	-F _{z,rec} [kN]	-F _{z,rec} [kN] in combina- tion with X-BT only
2330973	Pipe shoe MP-PS L2-2 21-26 1/2" OC	16.25	16.25	16.25	3.91	19.76	15.20	14.81
2330974	Pipe shoe MP-PS L2-2 26-31 3/4" OC	16.44	16.44	16.44	3.81	19.76	15.20	14.81
2330975	Pipe shoe MP-PS L2-2 32-37 1" OC	16.67	16.67	16.67	3.69	19.76	15.20	14.81
2330976	Pipe shoe MP-PS L2-2 38-44 1-1/4" OC	16.98	16.98	16.98	3.54	19.76	15.20	14.81
2330977	Pipe shoe MP-PS L2-2 45-51 1-1/2" OC	17.20	17.20	17.20	3.45	19.76	15.20	14.81
2330978	Pipe shoe MP-PS L2-2 52-58 OC	17.39	17.39	17.39	3.37	19.76	15.20	14.81
2330979	Pipe shoe MP-PS L2-2 59-65 2" OC	17.61	17.61	17.61	3.28	19.76	15.20	14.81
2330980	Pipe shoe MP-PS L2-2 68-74 OC	17.95	17.95	17.95	3.15	19.76	15.20	14.81
2330981	Pipe shoe MP-PS L2-2 75-81 2-1/2" OC	18.06	18.06	18.06	3.08	19.76	15.20	14.81
2330982	Pipe shoe MP-PS L2-2 88-94 3" OC	18.61	18.61	18.61	2.93	19.76	15.20	14.81
2330983	Pipe shoe MP-PS L2-2 100-108 3-1/2" OC	19.06	19.06	19.06	2.80	19.76	15.20	14.81
2330984	Pipe shoe MP-PS L2-2 110-118 4" OC	19.50	19.50	19.50	2.68	19.76	15.20	14.81
2330985	Pipe shoe MP-PS L2-2 125-133 OC	19.88	19.88	19.88	2.58	19.76	15.20	14.81
2330986	Pipe shoe MP-PS L2-2 136-144 5" OC	20.45	20.45	20.45	2.46	19.76	15.20	14.81
2330987	Pipe shoe MP-PS L2-2 152-162 OC	21.06	21.06	21.06	2.32	19.76	15.20	14.81
2330988	Pipe shoe MP-PS L2-2 163-173 6" OC	21.39	21.39	21.39	2.26	19.76	15.20	14.81
2330989	Pipe shoe MP-PS L2-2 192-202 7" OC	22.28	22.28	22.28	2.11	19.76	15.20	14.81
2330990	Pipe shoe MP-PS L2-2 217-227 8" OC	23.16	23.16	23.16	1.97	19.76	15.20	14.81
2330991	Pipe shoe MP-PS L2-2 244-254 OC	24.24	24.00	24.24	1.83	19.76	15.20	14.81
2330992	Pipe shoe MP-PS L2-2 267-277 10" OC	25.05	24.00	25.05	1.74	19.76	15.20	14.81
2330993	Pipe shoe MP-PS L2-2 318-328 12" OC	26.48	24.00	25.20	1.56	19.76	15.20	14.81

Notes

Shown EN1993-1-1 load values are recommended values with partial safety factors for action and resistance included. Design value in X & Y directions = 1.0 x recommended value. Design value in Z direction = 1.35 x recommended value

MT-TFB OC and Hex M10 8.8 bolts: partial safety factors on reaction side of 1.0 in X and Y directions and 1.35 in Z direction

HST3: no edge distance and spacing influence, minimum base material thickness considered, cracked concrete C 20/25, f_{ck,cube}=25 N/mm², partial safety factors on reaction side of 1.0 in X and Y directions and 1.35 in Z direction.

Interaction formula

$$\frac{F_{x,exp}}{F_{x,rec}} + \frac{F_{y,exp}}{F_{y,rec}} + \frac{F_{z,exp}}{F_{z,rec}} \leq 1.0$$

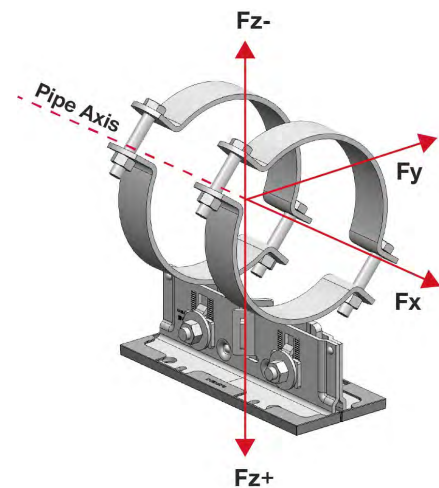

PIPE SHOE MP-PS M2-2

General

Media temperature limits: -20 °C to +300 °C

Height adjustability: 116 - 171 mm (with sliding plate)
113 - 168 mm (without sliding plate)

Slope adjustability: 12° (21%)

Mass per Pipe Shoe version:

Item no.	Pipe Shoe version	Nominal height	DN (mm)	Mass (kg)
2330994	Pipe shoe MP-PS M2-2 21-26 1/2" OC	150	DN15	3.76
2330995	Pipe shoe MP-PS M2-2 26-31 3/4" OC	150	DN20	3.80
2330996	Pipe shoe MP-PS M2-2 32-37 1" OC	150	DN25	3.85
2330997	Pipe shoe MP-PS M2-2 38-44 1-1/4" OC	150	DN32	3.88
2330998	Pipe shoe MP-PS M2-2 45-51 1-1/2" OC	150	DN40	3.94
2330970	Pipe shoe MP-PS M2-2 52-58 OC	150	OD52-58	4.31
2330971	Pipe shoe MP-PS M2-2 59-65 2" OC	150	DN50	4.39
2330972	Pipe shoe MP-PS M2-2 68-74 OC	150	OD68-74	4.48
2330999	Pipe shoe MP-PS M2-2 75-81 2-1/2" OC	150	DN65	4.55
2331000	Pipe shoe MP-PS M2-2 88-94 3" OC	150	DN80	4.66
2331001	Pipe shoe MP-PS M2-2 100-108 3-1/2" OC	150	OD100-108	4.77
2331002	Pipe shoe MP-PS M2-2 110-118 4" OC	150	DN100	4.86
2331003	Pipe shoe MP-PS M2-2 125-133 OC	150	OD125-133	5.01
2331004	Pipe shoe MP-PS M2-2 136-144 5" OC	150	DN125	5.13
2331005	Pipe shoe MP-PS M2-2 152-162 OC	150	OD152-162	5.31
2331006	Pipe shoe MP-PS M2-2 163-173 6" OC	150	DN150	5.42
2331007	Pipe shoe MP-PS M2-2 192-202 7" OC	150	OD192-202	6.75
2331008	Pipe shoe MP-PS M2-2 217-227 8" OC	150	DN200	7.13
2331009	Pipe shoe MP-PS M2-2 244-254 OC	150	OD244-254	7.99
2331010	Pipe shoe MP-PS M2-2 267-277 10" OC	150	DN250	8.33
2331011	Pipe shoe MP-PS M2-2 318-328 12" OC	150	DN300	9.07



Corrosion protection:

Component	Coating system	Zinc thickness, min. local (µm)
Top pipe ring	HDG per ISO 1461	55
Bottom pipe ring and midplate	HDG per ISO 1461	70
Baseplate	Continuously hot-dip Zinc-Magnesium coated per EN 10346	17
Serrated washers	Continuously hot-dip Zinc-Magnesium coated per EN 10346	17
Bolts; Nuts	HDG per ISO 10684	40;45

Material properties:

Component/Material	min. Yield strength	min. Ultimate strength	Modulus of elasticity	Shear modulus
Pipe rings and midplate S235JR (DIN EN10025-2)	$f_y = 235 \frac{N}{mm^2}$	$f_u = 360 \frac{N}{mm^2}$	$E = 210000 \frac{N}{mm^2}$	$G = 80769 \frac{N}{mm^2}$
Baseplate and serrated washer S280GD (EN 10346) POSMAC-C MOD	$f_y = 280 \frac{N}{mm^2}$	$f_u = 360 \frac{N}{mm^2}$	$E = 210000 \frac{N}{mm^2}$	$G = 80769 \frac{N}{mm^2}$
Bolts; Nuts F Class 8.8 (ISO 898-1); Grade 8 (ISO 898-2)	$f_y = 640 \frac{N}{mm^2}$	$f_u = 800 \frac{N}{mm^2}$	$E = 210000 \frac{N}{mm^2}$	$G = 80769 \frac{N}{mm^2}$
Sliding plates PA66-GF30	Static friction coefficient values: Hot Dip Galvanized mating surface: 0.13 Zinc-Magnesium mating surface: 0.15 Zinc Electrogalvanised mating surface: 0.18			
Values for Modulus of Elasticity and Shear Modulus are according to EN 1993-1-1 and used for all Eurocode calculations Friction coefficient per ASTM D1894-14				

DESIGN LOADING CAPACITY – 3D

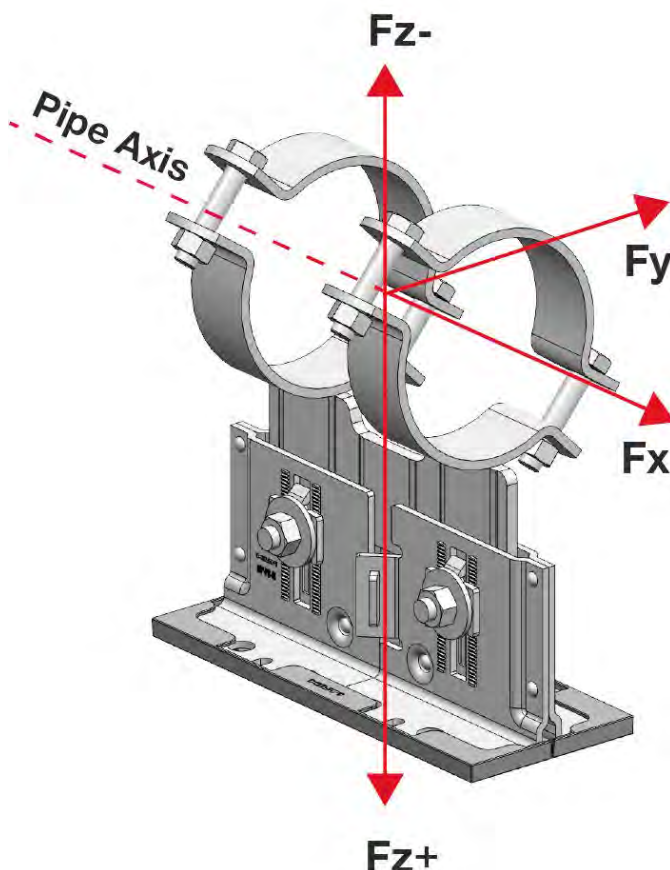
Notes for load data

Load capacity given at delivery height = 150mm BOP (Bottom of pipe).

Point of load application = pipe center line (X-axis).

Load capacity given at room temperature.

Temperature correction factors apply:

- Per VGB-R-510 for load reported acc to EN13480-3

- Per EN 1993-1-2 for loads reported acc to EN1993-1-1

Temperature distribution on pipe shoe components per EN13480-3

Failure locations per force direction:

Fx – deformation of pipe ring

Fy – deformation of baseplate

+Fz, -Fz – ultimate failure at baseplate serrations

Published loads are based on static loading conditions and mounting according to IFU. Non-static forces must be separately considered during design.

Below published load data is applicable for pipe shoes:

- welded to steel according to IFU
- mounted with MT-TFB OC bolts on MT girders
- mounted with Hex M10 8.8 class bolts on I-beams
- mounted with HST3 Stud Anchors
- mounted with X-BT/ F-BT threaded stud

In case of mounting, following configuration has been considered for load data in combination with the closest holes to the center of gravity:

Pipe shoe configuration	Number of fixation elements, pcs
1-1	2
2-2	4
4-2	8

For all other required loads (i.e. different height, -slope,...) please use Fixpoint Calculator

Recommended loads per EN13480-3

Item No.	Pipe Shoe version	+/-F _{x,rec} [kN]	+/-F _{y,rec} [kN]	+F _{z,rec} [kN]	-F _{z,rec} [kN]
2330994	Pipe shoe MP-PS M2-2 21-26 1/2" OC	14.20	2.41	17.57	13.44
2330995	Pipe shoe MP-PS M2-2 26-31 3/4" OC	14.33	2.37	17.57	13.44
2330996	Pipe shoe MP-PS M2-2 32-37 1" OC	14.50	2.32	17.57	13.44
2330997	Pipe shoe MP-PS M2-2 38-44 1-1/4" OC	14.71	2.26	17.57	13.44
2330998	Pipe shoe MP-PS M2-2 45-51 1-1/2" OC	14.85	2.23	17.57	13.44
2330970	Pipe shoe MP-PS M2-2 52-58 OC	14.99	2.19	17.57	13.44
2330971	Pipe shoe MP-PS M2-2 59-65 2" OC	15.14	2.15	17.57	13.44
2330972	Pipe shoe MP-PS M2-2 68-74 OC	15.38	2.09	17.57	13.44
2330999	Pipe shoe MP-PS M2-2 75-81 2-1/2" OC	15.53	2.06	17.57	13.44
2331000	Pipe shoe MP-PS M2-2 88-94 3" OC	15.84	1.99	17.57	13.44
2331001	Pipe shoe MP-PS M2-2 100-108 3-1/2" OC	16.15	1.93	17.57	13.44
2331002	Pipe shoe MP-PS M2-2 110-118 4" OC	16.46	1.87	17.57	13.44
2331003	Pipe shoe MP-PS M2-2 125-133 OC	16.71	1.82	17.57	13.44
2331004	Pipe shoe MP-PS M2-2 136-144 5" OC	17.07	1.76	17.57	13.44
2331005	Pipe shoe MP-PS M2-2 152-162 OC	17.54	1.69	17.57	13.44
2331006	Pipe shoe MP-PS M2-2 163-173 6" OC	17.77	1.66	17.57	13.44
2331007	Pipe shoe MP-PS M2-2 192-202 7" OC	18.38	1.57	17.57	13.44
2331008	Pipe shoe MP-PS M2-2 217-227 8" OC	18.58	1.49	17.57	13.44
2331009	Pipe shoe MP-PS M2-2 244-254 OC	18.58	1.41	17.57	13.44
2331010	Pipe shoe MP-PS M2-2 267-277 10" OC	18.58	1.35	17.57	13.44
2331011	Pipe shoe MP-PS M2-2 318-328 12" OC	18.58	1.24	17.57	13.44

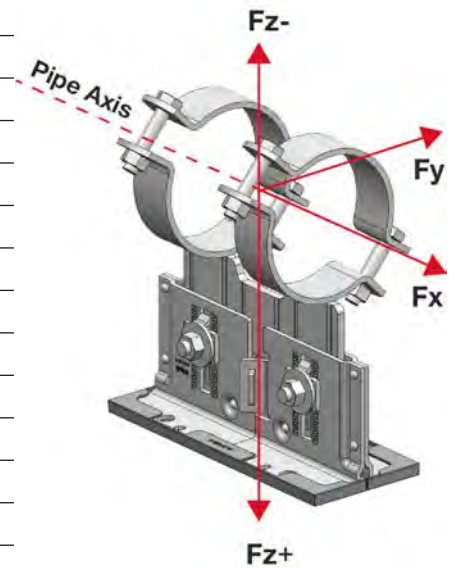
Notes

Shown load data is applicable for pipe shoes without considering the load capacity of the sub-structure and base material.

Interaction formula

$$\left(\frac{F_{x,exp}}{F_{x,rec}}\right)^2 + \left(\frac{F_{y,exp}}{F_{y,rec}}\right)^2 + \left(\frac{F_{z,exp}}{F_{z,rec}}\right)^2 + \frac{F_{x,exp}}{F_{x,rec}} * \frac{F_{y,exp}}{F_{y,rec}} + \frac{F_{x,exp}}{F_{x,rec}} * \frac{F_{z,exp}}{F_{z,rec}} + \frac{F_{y,exp}}{F_{y,rec}} * \frac{F_{z,exp}}{F_{z,rec}} \leq 1.0$$

Recommended loads per EN1993-1-1

Item No.	Pipe Shoe version	+/-F _{x,rec} [kN]	+/-F _{x,rec} [kN] in combi- nation with X-BT only	+/-F _{x,rec} [kN] in combi- nation with F-BT only	+/-F _{y,rec} [kN]	+F _{z,rec} [kN]	-F _{z,rec} [kN]	-F _{z,rec} [kN] in combi- nation with X-BT only
2330994	Pipe shoe MP-PS M2-2 21-26 1/2" OC	20.45	20.45	20.45	2.45	19.76	15.20	14.81
2330995	Pipe shoe MP-PS M2-2 26-31 3/4" OC	20.64	20.63	20.63	2.41	19.76	15.20	14.81
2330996	Pipe shoe MP-PS M2-2 32-37 1" OC	20.88	20.87	20.87	2.36	19.76	15.20	14.81
2330997	Pipe shoe MP-PS M2-2 38-44 1-1/4" OC	21.18	21.18	21.18	2.30	19.76	15.20	14.81
2330998	Pipe shoe MP-PS M2-2 45-51 1-1/2" OC	21.39	21.39	21.39	2.26	19.76	15.20	14.81
2330970	Pipe shoe MP-PS M2-2 52-58 OC	21.59	21.59	21.59	2.23	19.76	15.20	14.81
2330971	Pipe shoe MP-PS M2-2 59-65 2" OC	21.81	21.81	21.81	2.19	19.76	15.20	14.81
2330972	Pipe shoe MP-PS M2-2 68-74 OC	22.15	22.15	22.15	2.13	19.76	15.20	14.81
2330999	Pipe shoe MP-PS M2-2 75-81 2-1/2" OC	22.36	22.25	22.25	2.09	19.76	15.20	14.81
2331000	Pipe shoe MP-PS M2-2 88-94 3" OC	22.81	22.81	22.81	2.03	19.76	15.20	14.81
2331001	Pipe shoe MP-PS M2-2 100-108 3-1/2" OC	23.25	23.25	23.25	1.96	19.76	15.20	14.81
2331002	Pipe shoe MP-PS M2-2 110-118 4" OC	23.70	23.70	23.70	1.90	19.76	15.20	14.81
2331003	Pipe shoe MP-PS M2-2 125-133 OC	24.07	24.00	24.07	1.85	19.76	15.20	14.81
2331004	Pipe shoe MP-PS M2-2 136-144 5" OC	24.58	24.00	24.64	1.79	19.76	15.20	14.81
2331005	Pipe shoe MP-PS M2-2 152-162 OC	25.26	24.00	25.20	1.72	19.76	15.20	14.81
2331006	Pipe shoe MP-PS M2-2 163-173 6" OC	25.58	24.00	25.20	1.68	19.76	15.20	14.81
2331007	Pipe shoe MP-PS M2-2 192-202 7" OC	26.47	24.00	25.20	1.60	19.76	15.20	14.81
2331008	Pipe shoe MP-PS M2-2 217-227 8" OC	26.48	24.00	25.20	1.52	19.76	15.20	14.81
2331009	Pipe shoe MP-PS M2-2 244-254 OC	26.48	24.00	25.20	1.43	19.76	15.20	14.81
2331010	Pipe shoe MP-PS M2-2 267-277 10" OC	26.48	24.00	25.20	1.37	19.76	15.20	14.81
2331011	Pipe shoe MP-PS M2-2 318-328 12" OC	26.48	24.00	25.20	1.26	19.76	15.20	14.81

Notes

Shown EN1993-1-1 load values are recommended values with partial safety factors for action and resistance included. Design value in X & Y directions = 1.0 x recommended value. Design value in Z direction = 1.35 x recommended value.

MT-TFB OC and Hex M10 8.8 bolts and X-BT-MR M10/W10: partial safety factors on reaction side of 1.0 in X and Y directions and 1.35 in Z direction

HST3: no edge distance and spacing influence, minimum base material thickness considered, cracked concrete C 20/25, f_{ck,cube}=25 N/mm², partial safety factors on reaction side of 1.0 in X and Y directions and 1.35 in Z direction.

Interaction formula

$$\frac{F_{x,exp}}{F_{x,rec}} + \frac{F_{y,exp}}{F_{y,rec}} + \frac{F_{z,exp}}{F_{z,rec}} \leq 1.0$$

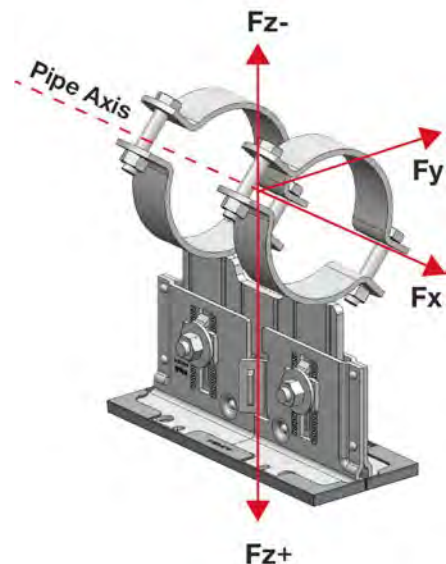

PIPE SHOE MP-PS H2-2

General

Media temperature limits: -20 °C to +300 °C

Height adjustability: 171 - 223.5 mm (with sliding plate)
168 - 220.5 mm (without sliding plate)

Slope adjustability: 12° (21%)

Mass per Pipe Shoe version:

Item no.	Pipe Shoe version	Nominal height	DN (mm)	Mass (kg)
2331012	Pipe shoe MP-PS H2-2 21-26 1/2" OC	200	DN15	4.57
2331013	Pipe shoe MP-PS H2-2 26-31 3/4" OC	200	DN20	4.61
2331014	Pipe shoe MP-PS H2-2 32-37 1" OC	200	DN25	4.66
2331015	Pipe shoe MP-PS H2-2 38-44 1-1/4" OC	200	DN32	4.69
2331016	Pipe shoe MP-PS H2-2 45-51 1-1/2" OC	200	DN40	4.75
2331017	Pipe shoe MP-PS H2-2 52-58 OC	200	OD52-58	5.12
2331018	Pipe shoe MP-PS H2-2 59-65 2" OC	200	DN50	5.20
2331019	Pipe shoe MP-PS H2-2 68-74 OC	200	OD68-74	5.29
2331020	Pipe shoe MP-PS H2-2 75-81 2-1/2" OC	200	DN65	5.36
2331021	Pipe shoe MP-PS H2-2 88-94 3" OC	200	DN80	5.47
2331022	Pipe shoe MP-PS H2-2 100-108 3-1/2" OC	200	OD100-108	5.58
2331023	Pipe shoe MP-PS H2-2 110-118 4" OC	200	DN100	5.67
2331024	Pipe shoe MP-PS H2-2 125-133 OC	200	OD125-133	5.82
2331025	Pipe shoe MP-PS H2-2 136-144 5" OC	200	DN125	5.94
2331026	Pipe shoe MP-PS H2-2 152-162 OC	200	OD152-162	6.12
2331027	Pipe shoe MP-PS H2-2 163-173 6" OC	200	DN150	6.23
2331028	Pipe shoe MP-PS H2-2 192-202 7" OC	200	OD192-202	7.56
2331029	Pipe shoe MP-PS H2-2 217-227 8" OC	200	DN200	7.94
2331030	Pipe shoe MP-PS H2-2 244-254 OC	200	OD244-254	8.80
2331031	Pipe shoe MP-PS H2-2 267-277 10" OC	200	DN250	9.14
2331032	Pipe shoe MP-PS H2-2 318-328 12" OC	200	DN300	9.88



Corrosion protection:

Component	Coating system	Zinc thickness, min. local (µm)
Top pipe ring	HDG per ISO 1461	55
Bottom pipe ring and midplate	HDG per ISO 1461	70
Baseplate	Continuously hot-dip Zinc-Magnesium coated per EN 10346	17
Serrated washers	Continuously hot-dip Zinc-Magnesium coated per EN 10346	17
Bolts; Nuts	HDG per ISO 10684	40;45

Material properties:

Component/Material	min. Yield strength	min. Ultimate strength	Modulus of elasticity	Shear modulus
Pipe rings and midplate S235JR (DIN EN10025-2)	$f_y = 235 \frac{N}{mm^2}$	$f_u = 360 \frac{N}{mm^2}$	$E = 210000 \frac{N}{mm^2}$	$G = 80769 \frac{N}{mm^2}$
Baseplate and serrated washer S280GD (EN 10346) POSMAC-C MOD	$f_y = 280 \frac{N}{mm^2}$	$f_u = 360 \frac{N}{mm^2}$	$E = 210000 \frac{N}{mm^2}$	$G = 80769 \frac{N}{mm^2}$
Bolts; Nuts F Class 8.8 (ISO 898-1); Grade 8 (ISO 898-2)	$f_y = 640 \frac{N}{mm^2}$	$f_u = 800 \frac{N}{mm^2}$	$E = 210000 \frac{N}{mm^2}$	$G = 80769 \frac{N}{mm^2}$
Sliding plates PA66-GF30	Static friction coefficient values: Hot Dip Galvanized mating surface: 0.13 Zinc-Magnesium mating surface: 0.15 Zinc Electrogalvanised mating surface: 0.18			
Values for Modulus of Elasticity and Shear Modulus are according to EN 1993-1-1 and used for all Eurocode calculations Friction coefficient per ASTM D1894-14				

DESIGN LOADING CAPACITY – 3D

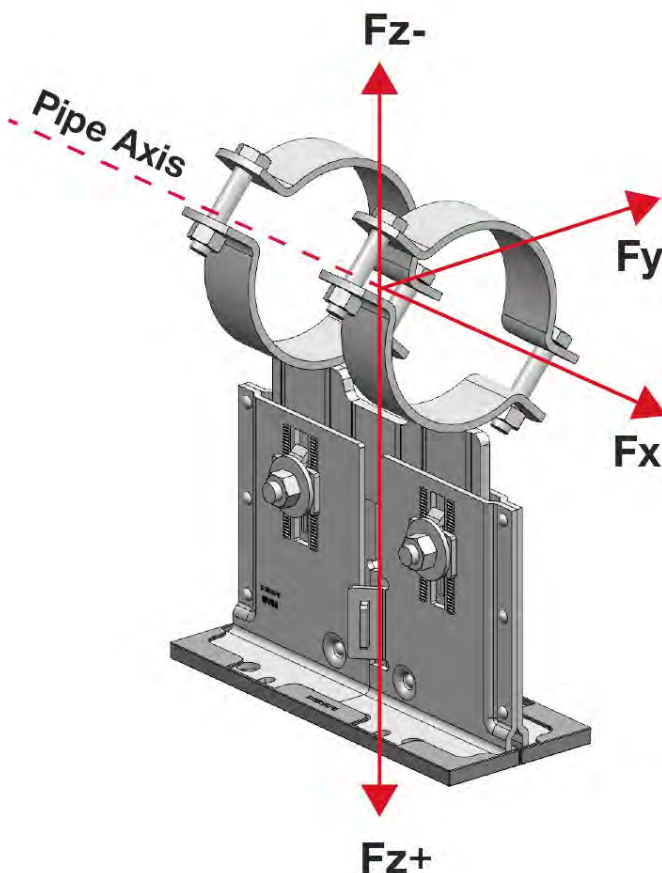
Notes for load data

Load capacity given at delivery height = 200mm BOP (Bottom of pipe).

Point of load application = pipe center line (X-axis).

Load capacity given at room temperature.

Temperature correction factors apply:

- Per VGB-R-510 for load reported acc to

EN13480-3

- Per EN 1993-1-2 for loads reported acc to EN1993-1-1

Temperature distribution on pipe shoe components per EN13480-3

Failure locations per force direction:

Fx - deformation of pipe ring

Fy - deformation of baseplate

+Fz, -Fz - ultimate failure at baseplate serrations

Published loads are based on static loading

conditions and mounting according to IFU. Non-static forces must be separately considered during design.

Below published load data is applicable for pipe shoes:

- welded to steel according to IFU
- mounted with MT-TFB OC bolts on MT girders
- mounted with Hex M10 8.8 class bolts on I-beams
- mounted with HST3 Stud Anchors
- mounted with X-BT/ F-BT threaded stud

In case of mounting, following configuration has been considered for load data in combination with the closest holes to the center of gravity:

Pipe shoe configuration	Number of fixation elements, pcs
1-1	2
2-2	4
4-2	8

For all other required loads

(i.e. different height, -slope,...)

please use Fixpoint Calculator

Recommended loads per EN13480-3

Item No.	Pipe Shoe version	+/-F _{x,rec} [kN]	+/-F _{y,rec} [kN]	+F _{z,rec} [kN]	-F _{z,rec} [kN]
2331012	Pipe shoe MP-PS H2-2 21-26 1/2" OC	16.62	1.84	17.57	13.44
2331013	Pipe shoe MP-PS H2-2 26-31 3/4" OC	16.76	1.82	17.57	13.44
2331014	Pipe shoe MP-PS H2-2 32-37 1" OC	16.93	1.79	17.57	13.44
2331015	Pipe shoe MP-PS H2-2 38-44 1-1/4" OC	17.14	1.75	17.57	13.44
2331016	Pipe shoe MP-PS H2-2 45-51 1-1/2" OC	17.28	1.73	17.57	13.44
2331017	Pipe shoe MP-PS H2-2 52-58 OC	17.42	1.71	17.57	13.44
2331018	Pipe shoe MP-PS H2-2 59-65 2" OC	17.57	1.68	17.57	13.44
2331019	Pipe shoe MP-PS H2-2 68-74 OC	17.81	1.65	17.57	13.44
2331020	Pipe shoe MP-PS H2-2 75-81 2-1/2" OC	17.95	1.63	17.57	13.44
2331021	Pipe shoe MP-PS H2-2 88-94 3" OC	18.27	1.59	17.57	13.44
2331022	Pipe shoe MP-PS H2-2 100-108 3-1/2" OC	18.58	1.55	17.57	13.44
2331023	Pipe shoe MP-PS H2-2 110-118 4" OC	18.58	1.51	17.57	13.44
2331024	Pipe shoe MP-PS H2-2 125-133 OC	18.58	1.48	17.57	13.44
2331025	Pipe shoe MP-PS H2-2 136-144 5" OC	18.58	1.44	17.57	13.44
2331026	Pipe shoe MP-PS H2-2 152-162 OC	18.58	1.39	17.57	13.44
2331027	Pipe shoe MP-PS H2-2 163-173 6" OC	18.58	1.36	17.57	13.44
2331028	Pipe shoe MP-PS H2-2 192-202 7" OC	18.58	1.31	17.57	13.44
2331029	Pipe shoe MP-PS H2-2 217-227 8" OC	18.58	1.25	17.57	13.44
2331030	Pipe shoe MP-PS H2-2 244-254 OC	18.58	1.19	17.57	13.44
2331031	Pipe shoe MP-PS H2-2 267-277 10" OC	18.58	1.15	17.57	13.44
2331032	Pipe shoe MP-PS H2-2 318-328 12" OC	18.58	1.07	17.57	13.44

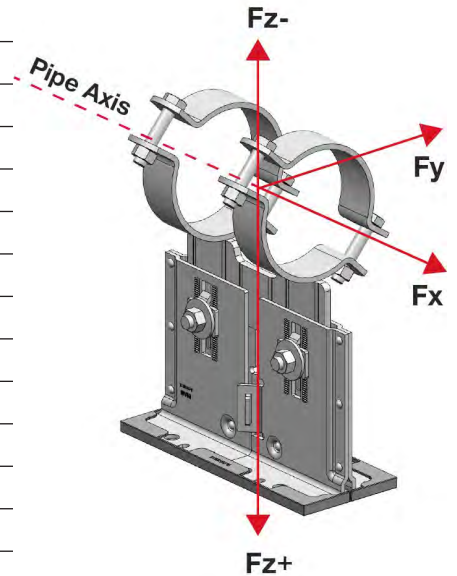
Notes

Shown load data is applicable for pipe shoes without considering the load capacity of the sub-structure and base material.

Interaction formula

$$\left(\frac{F_{x,exp}}{F_{x,rec}}\right)^2 + \left(\frac{F_{y,exp}}{F_{y,rec}}\right)^2 + \left(\frac{F_{z,exp}}{F_{z,rec}}\right)^2 + \frac{F_{x,exp}}{F_{x,rec}} * \frac{F_{y,exp}}{F_{y,rec}} + \frac{F_{x,exp}}{F_{x,rec}} * \frac{F_{z,exp}}{F_{z,rec}} + \frac{F_{y,exp}}{F_{y,rec}} * \frac{F_{z,exp}}{F_{z,rec}} \leq 1.0$$

Recommended loads per EN1993-1-1

Item No.	Pipe Shoe version	+/-F _{x,rec} [kN]	+/-F _{x,rec} [kN] in combi- nation with X-BT only	+/-F _{x,rec} [kN] in combi- nation with F-BT only	+/-F _{y,rec} [kN]	+F _{z,rec} [kN]	-F _{z,rec} [kN]	-F _{z,rec} [kN] in combi- nation with X-BT only
2331012	Pipe shoe MP-PS H2-2 21-26 1/2" OC	23.94	23.94	23.94	1.87	19.76	15.20	14.81
2331013	Pipe shoe MP-PS H2-2 26-31 3/4" OC	24.14	24.00	24.13	1.85	19.76	15.20	14.81
2331014	Pipe shoe MP-PS H2-2 32-37 1" OC	24.37	24.00	24.36	1.82	19.76	15.20	14.81
2331015	Pipe shoe MP-PS H2-2 38-44 1-1/4" OC	24.68	24.00	24.67	1.78	19.76	15.20	14.81
2331016	Pipe shoe MP-PS H2-2 45-51 1-1/2" OC	24.88	24.00	24.88	1.76	19.76	15.20	14.81
2331017	Pipe shoe MP-PS H2-2 52-58 OC	25.08	24.00	25.08	1.74	19.76	15.20	14.81
2331018	Pipe shoe MP-PS H2-2 59-65 2" OC	25.30	24.00	25.20	1.71	19.76	15.20	14.81
2331019	Pipe shoe MP-PS H2-2 68-74 OC	25.64	24.00	25.20	1.68	19.76	15.20	14.81
2331020	Pipe shoe MP-PS H2-2 75-81 2-1/2" OC	25.86	24.00	25.20	1.65	19.76	15.20	14.81
2331021	Pipe shoe MP-PS H2-2 88-94 3" OC	26.30	24.00	25.20	1.61	19.76	15.20	14.81
2331022	Pipe shoe MP-PS H2-2 100-108 3-1/2" OC	26.48	24.00	25.20	1.57	19.76	15.20	14.81
2331023	Pipe shoe MP-PS H2-2 110-118 4" OC	26.48	24.00	25.20	1.53	19.76	15.20	14.81
2331024	Pipe shoe MP-PS H2-2 125-133 OC	26.48	24.00	25.20	1.50	19.76	15.20	14.81
2331025	Pipe shoe MP-PS H2-2 136-144 5" OC	26.48	24.00	25.20	1.46	19.76	15.20	14.81
2331026	Pipe shoe MP-PS H2-2 152-162 OC	26.48	24.00	25.20	1.41	19.76	15.20	14.81
2331027	Pipe shoe MP-PS H2-2 163-173 6" OC	26.48	24.00	25.20	1.39	19.76	15.20	14.81
2331028	Pipe shoe MP-PS H2-2 192-202 7" OC	26.48	24.00	25.20	1.33	19.76	15.20	14.81
2331029	Pipe shoe MP-PS H2-2 217-227 8" OC	26.48	24.00	25.20	1.27	19.76	15.20	14.81
2331030	Pipe shoe MP-PS H2-2 244-254 OC	26.48	24.00	25.20	1.21	19.76	15.20	14.81
2331031	Pipe shoe MP-PS H2-2 267-277 10" OC	26.48	24.00	25.20	1.17	19.76	15.20	14.81
2331032	Pipe shoe MP-PS H2-2 318-328 12" OC	26.48	24.00	25.20	1.09	19.76	15.20	14.81

Notes

Shown EN1993-1-1 load values are recommended values with partial safety factors for action and resistance included. Design value in X & Y directions = 1.0 x recommended value. Design value in Z direction = 1.35 x recommended value.

MT-TFB OC and Hex M10 8.8 bolts and X-BT-MR M10/W10: partial safety factors on reaction side of 1.0 in X and Y directions and 1.35 in Z direction

HST3: no edge distance and spacing influence, minimum base material thickness considered, cracked concrete C 20/25, f_{ck,cube}=25 N/mm², partial safety factors on reaction side of 1.0 in X and Y directions and 1.35 in Z direction.

Interaction formula

$$\frac{F_{x,exp}}{F_{x,rec}} + \frac{F_{y,exp}}{F_{y,rec}} + \frac{F_{z,exp}}{F_{z,rec}} \leq 1.0$$

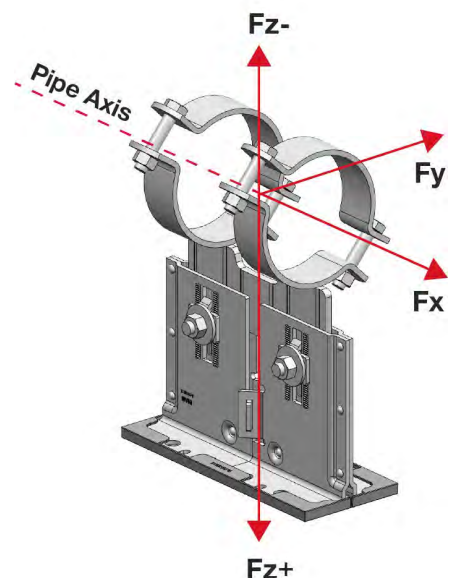

PIPE SHOE MP-PS L4-2

General

Media temperature limits: -20 °C to +300 °C

Height adjustability: 88.5 - 116 mm (with sliding plate)
85.5 - 113 mm (without sliding plate)

Slope adjustability: 12° (21%)

Mass per Pipe Shoe version:

Item no.	Pipe Shoe version	Nominal height	DN (mm)	Mass (kg)
2331033	Pipe shoe MP-PS L4-2 217-227 8" OC	90	DN200	9.88
2331034	Pipe shoe MP-PS L4-2 244-254 OC	90	OD244-254	11.12
2331035	Pipe shoe MP-PS L4-2 267-277 10" OC	90	DN250	11.46
2331036	Pipe shoe MP-PS L4-2 318-328 12" OC	90	DN300	12.20
2331037	Pipe shoe MP-PS L4-2 350-360 14" OC	90	DN350	13.81
2331038	Pipe shoe MP-PS L4-2 401-411 16" OC	90	DN400	14.68
2331039	Pipe shoe MP-PS L4-2 452-462 18" OC	90	DN450	15.56
2331040	Pipe shoe MP-PS L4-2 503-513 20" OC	90	DN500	16.47
2331041	Pipe shoe MP-PS L4-2 605-615 24" OC	90	DN600	18.26



Corrosion protection:

Component	Coating system	Zinc thickness, min. local (µm)
Top pipe ring	HDG per ISO 1461	55
Bottom pipe ring and midplate	HDG per ISO 1461	70
Baseplate	Continuously hot-dip Zinc-Magnesium coated per EN 10346	17
Serrated washers	Continuously hot-dip Zinc-Magnesium coated per EN 10346	17
Bolts; Nuts	HDG per ISO 10684	40;45

Material properties:

Component/Material	min. Yield strength	min. Ultimate strength	Modulus of elasticity	Shear modulus
Pipe rings and midplate S235JR (DIN EN10025-2)	$f_y = 235 \frac{N}{mm^2}$	$f_u = 360 \frac{N}{mm^2}$	$E = 210000 \frac{N}{mm^2}$	$G = 80769 \frac{N}{mm^2}$
Baseplate and serrated washer S280GD (EN 10346) POSMAC-C MOD	$f_y = 280 \frac{N}{mm^2}$	$f_u = 360 \frac{N}{mm^2}$	$E = 210000 \frac{N}{mm^2}$	$G = 80769 \frac{N}{mm^2}$
Bolts; Nuts; Threaded rods F Class 8.8 (ISO 898-1); Grade 8 (ISO 898-2)	$f_y = 640 \frac{N}{mm^2}$	$f_u = 800 \frac{N}{mm^2}$	$E = 210000 \frac{N}{mm^2}$	$G = 80769 \frac{N}{mm^2}$
Sliding plates PA66-GF30	Static friction coefficient values: Hot Dip Galvanized mating surface: 0.13 Zinc-Magnesium mating surface: 0.15 Zinc Electrogalvanised mating surface: 0.18			
Values for Modulus of Elasticity and Shear Modulus are according to EN 1993-1-1 and used for all Eurocode calculations Friction coefficient per ASTM D1894-14				

DESIGN LOADING CAPACITY – 3D

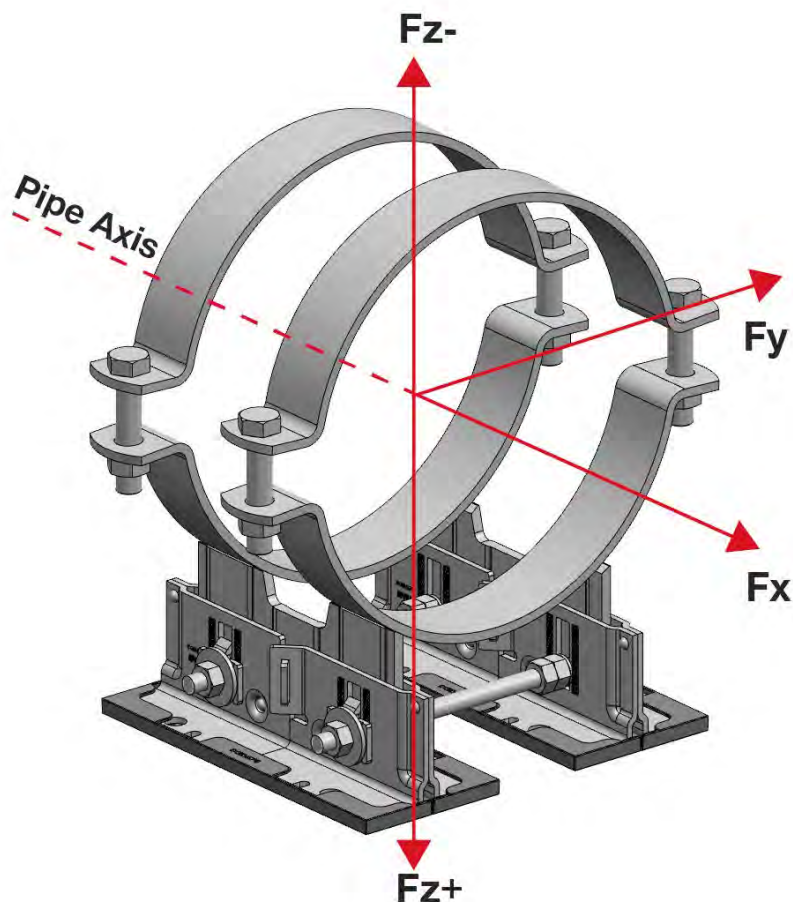
Notes for load data

Load capacity given at delivery height = 90mm BOP (Bottom of pipe).

Point of load application = pipe center line (X-axis).

Load capacity given at room temperature.

Temperature correction factors apply:

- Per VGB-R-510 for load reported acc to EN13480-3

- Per EN 1993-1-2 for loads reported acc to EN1993-1-1

Temperature distribution on pipe shoe components per EN13480-3

Failure locations per force direction:

F_x – deformation of pipe ring

F_y – deformation of baseplate

$+F_z$, $-F_z$ – ultimate failure at baseplate serrations

Published loads are based on static loading conditions and mounting according to IFU. Non-static forces must be separately considered during design.

Below published load data is applicable for pipe shoes:

- welded to steel according to IFU
- mounted with MT-TFB OC bolts on MT girders
- mounted with Hex M10 8.8 class bolts on I-beams
- mounted with HST3 Stud Anchors
- mounted with X-BT/ F-BT threaded stud

In case of mounting, following configuration has been considered for load data in combination with the closest holes to the center of gravity:

Pipe shoe configuration	Number of fixation elements, pcs
1-1	2
2-2	4
4-2	8

For all other required loads (i.e. different height, -slope,...) please use Fixpoint Calculator

Recommended loads per EN13480-3

Item No.	Pipe Shoe version	+/-F _{x,rec} [kN]	+/-F _{y,rec} [kN]	+F _{z,rec} [kN]	-F _{z,rec} [kN]
2331033	Pipe shoe MP-PS L4-2 217-227 8" OC	17.29	14.66	32.50	17.29
2331034	Pipe shoe MP-PS L4-2 244-254 OC	17.29	13.60	32.50	17.29
2331035	Pipe shoe MP-PS L4-2 267-277 10" OC	17.29	12.91	32.50	17.29
2331036	Pipe shoe MP-PS L4-2 318-328 12" OC	17.29	11.61	32.50	17.29
2331037	Pipe shoe MP-PS L4-2 350-360 14" OC	17.29	10.93	32.50	17.29
2331038	Pipe shoe MP-PS L4-2 401-411 16" OC	17.29	9.98	32.50	17.29
2331039	Pipe shoe MP-PS L4-2 452-462 18" OC	17.29	9.18	32.50	17.29
2331040	Pipe shoe MP-PS L4-2 503-513 20" OC	17.29	8.50	32.50	17.29
2331041	Pipe shoe MP-PS L4-2 605-615 24" OC	17.29	7.41	32.50	17.29

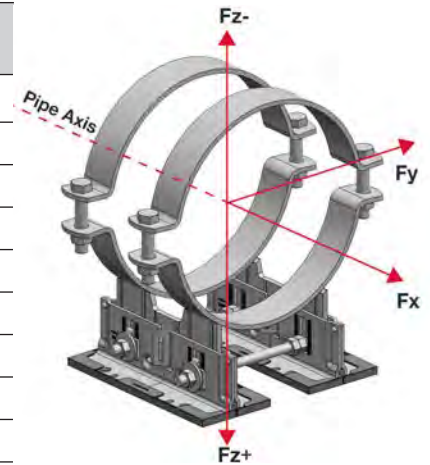
Notes

Shown load data is applicable for pipe shoes without considering the load capacity of the sub-structure and base material.

Interaction formula

$$\left(\frac{F_{x,exp}}{F_{x,rec}}\right)^2 + \left(\frac{F_{y,exp}}{F_{y,rec}}\right)^2 + \left(\frac{F_{z,exp}}{F_{z,rec}}\right)^2 + \frac{F_{x,exp}}{F_{x,rec}} * \frac{F_{y,exp}}{F_{y,rec}} + \frac{F_{x,exp}}{F_{x,rec}} * \frac{F_{z,exp}}{F_{z,rec}} + \frac{F_{y,exp}}{F_{y,rec}} * \frac{F_{z,exp}}{F_{z,rec}} \leq 1.0$$

Recommended loads per EN1993-1-1

Item No.	Pipe Shoe version	+/-F _{x,rec} [kN]	+/-F _{y,rec} [kN]	+/-F _{y,rec} [kN] in combi- nation with X-BT only	+F _{z,rec} [kN]	-F _{z,rec} [kN]	-F _{z,rec} [kN] in combi- nation with X-BT only
2331033	Pipe shoe MP-PS L4-2 217-227 8" OC	41.50	27.75	13.68	36.40	30.74	29.63
2331034	Pipe shoe MP-PS L4-2 244-254 OC	41.50	25.75	12.96	36.40	30.74	29.63
2331035	Pipe shoe MP-PS L4-2 267-277 10" OC	41.50	24.45	12.47	36.40	30.74	29.63
2331036	Pipe shoe MP-PS L4-2 318-328 12" OC	41.50	21.98	11.52	36.40	30.74	29.63
2331037	Pipe shoe MP-PS L4-2 350-360 14" OC	41.50	20.70	10.99	36.40	30.74	29.63
2331038	Pipe shoe MP-PS L4-2 401-411 16" OC	41.50	18.90	10.24	36.40	30.74	29.63
2331039	Pipe shoe MP-PS L4-2 452-462 18" OC	41.50	17.38	9.59	36.40	30.74	29.63
2331040	Pipe shoe MP-PS L4-2 503-513 20" OC	41.50	16.10	9.01	36.40	30.74	29.63
2331041	Pipe shoe MP-PS L4-2 605-615 24" OC	41.50	14.02	8.04	36.40	30.74	29.63

Notes

Shown EN1993-1-1 load values are recommended values with partial safety factors for action and resistance included. Design value in X & Y directions = 1.0 x recommended value. Design value in Z direction = 1.35 x recommended value.

MT-TFB OC and Hex M10 8.8 bolts and X-BT-MR M10/W10: partial safety factors on reaction side of 1.0 in X and Y directions and 1.35 in Z direction

HST3: no edge distance and spacing influence, minimum base material thickness considered, cracked concrete C 20/25, f_{ck,cube}=25 N/mm², partial safety factors on reaction side of 1.0 in X and Y directions and 1.35 in Z direction.

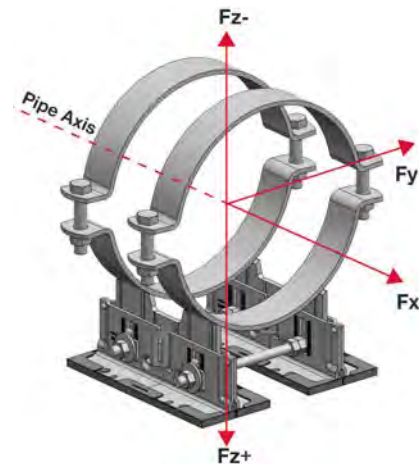
Interaction formula

$$\frac{F_{x,exp}}{F_{x,rec}} + \frac{F_{y,exp}}{F_{y,rec}} + \frac{F_{z,exp}}{F_{z,rec}} \leq 1.0$$

PIPE SHOE MP-PS M4-2

General

Media temperature limits: -20 °C to +300 °C

Height adjustability: 116 - 171 mm (with sliding plate)
113 - 168 mm (without sliding pate)

Slope adjustability: 12° (21%)

Mass per Pipe Shoe version:

Item no.	Pipe Shoe version	Nominal height	DN (mm)	Mass (kg)
2331042	Pipe shoe MP-PS M4-2 217-227 8" OC	150	DN200	11.16
2331043	Pipe shoe MP-PS M4-2 244-254 OC	150	OD244-254	12.40
2331044	Pipe shoe MP-PS M4-2 267-277 10" OC	150	DN250	12.74
2331045	Pipe shoe MP-PS M4-2 318-328 12" OC	150	DN300	13.48
2331046	Pipe shoe MP-PS M4-2 350-360 14" OC	150	DN350	15.09
2331047	Pipe shoe MP-PS M4-2 401-411 16" OC	150	DN400	15.95
2331048	Pipe shoe MP-PS M4-2 452-462 18" OC	150	DN450	16.84
2331049	Pipe shoe MP-PS M4-2 503-513 20" OC	150	DN500	17.75
2331050	Pipe shoe MP-PS M4-2 605-615 24" OC	150	DN600	19.54



Corrosion protection:

Component	Coating system	Zinc thickness, min. local (µm)
Top pipe ring	HDG per ISO 1461	55
Bottom pipe ring and midplate	HDG per ISO 1461	70
Baseplate	Continuously hot-dip Zinc-Magnesium coated per EN 10346	17
Serrated washers	Continuously hot-dip Zinc-Magnesium coated per EN 10346	17
Bolts; Nuts	HDG per ISO 10684	40;45

Material properties:

Component/Material	min. Yield strength	min. Ultimate strength	Modulus of elasticity	Shear modulus
Pipe rings and midplate S235JR (DIN EN10025-2)	$f_y = 235 \frac{N}{mm^2}$	$f_u = 360 \frac{N}{mm^2}$	$E = 210000 \frac{N}{mm^2}$	$G = 80769 \frac{N}{mm^2}$
Baseplate and serrated washer S280GD (EN 10346) POSMAC-C MOD	$f_y = 280 \frac{N}{mm^2}$	$f_u = 360 \frac{N}{mm^2}$	$E = 210000 \frac{N}{mm^2}$	$G = 80769 \frac{N}{mm^2}$
Bolts; Nuts; Threaded rods F Class 8.8 (ISO 898-1); Grade 8 (ISO 898-2)	$f_y = 640 \frac{N}{mm^2}$	$f_u = 800 \frac{N}{mm^2}$	$E = 210000 \frac{N}{mm^2}$	$G = 80769 \frac{N}{mm^2}$
Sliding plates PA66-GF30	Static friction coefficient values: Hot Dip Galvanized mating surface: 0.13 Zinc-Magnesium mating surface: 0.15 Zinc Electrogalvanised mating surface: 0.18			
Values for Modulus of Elasticity and Shear Modulus are according to EN 1993-1-1 and used for all Eurocode calculations Friction coefficient per ASTM D1894-14				

DESIGN LOADING CAPACITY – 3D

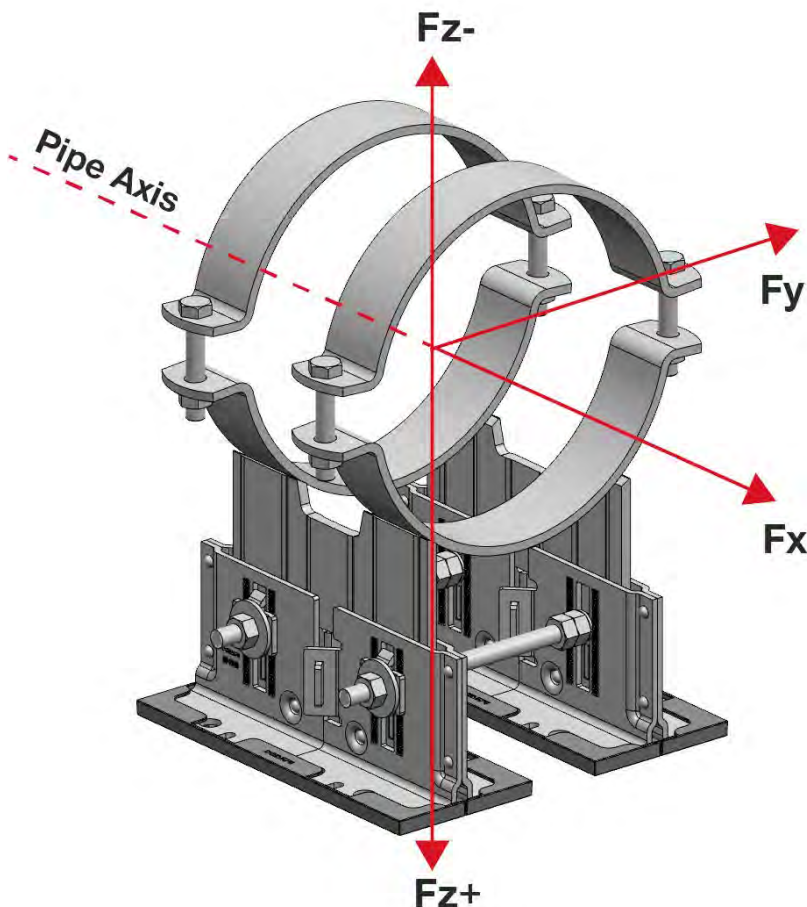
Notes for load data

Load capacity given at delivery height = 150mm BOP (Bottom of pipe).

Point of load application = pipe center line (X-axis).

Load capacity given at room temperature.

Temperature correction factors apply:

- Per VGB-R-510 for load reported acc to

EN13480-3

- Per EN 1993-1-2 for loads reported acc to EN1993-1-1

Temperature distribution on pipe shoe components per EN13480-3

Failure locations per force direction:

F_x – deformation of pipe ring

F_y – deformation of baseplate

+F_z, -F_z – ultimate failure at baseplate serrations

Published loads are based on static loading

conditions and mounting according to IFU. Non-static forces must be separately considered during design.

Below published load data is applicable for pipe shoes:

- welded to steel according to IFU
- mounted with MT-TFB OC bolts on MT girders
- mounted with Hex M10 8.8 class bolts on I-beams
- mounted with HST3 Stud Anchors
- mounted with X-BT/ F-BT threaded stud

In case of mounting, following configuration has been considered for load data in combination with the closest holes to the center of gravity:

Pipe shoe configuration	Number of fixation elements, pcs
1-1	2
2-2	4
4-2	8

For all other required loads

(i.e. different height, -slope,...)

please use Fixpoint Calculator

Recommended loads per EN13480-3

Item No.	Pipe Shoe version	+/-F _{x,rec} [kN]	+/-F _{y,rec} [kN]	+F _{z,rec} [kN]	-F _{z,rec} [kN]
2331042	Pipe shoe MP-PS M4-2 217-227 8" OC	13.83	11.27	32.50	17.29
2331043	Pipe shoe MP-PS M4-2 244-254 OC	13.83	10.64	32.50	17.29
2331044	Pipe shoe MP-PS M4-2 267-277 10" OC	13.83	10.21	32.50	17.29
2331045	Pipe shoe MP-PS M4-2 318-328 12" OC	13.83	9.38	32.50	17.29
2331046	Pipe shoe MP-PS M4-2 350-360 14" OC	13.83	8.93	32.50	17.29
2331047	Pipe shoe MP-PS M4-2 401-411 16" OC	13.83	8.29	32.50	17.29
2331048	Pipe shoe MP-PS M4-2 452-462 18" OC	13.83	7.73	32.50	17.29
2331049	Pipe shoe MP-PS M4-2 503-513 20" OC	13.83	7.24	32.50	17.29
2331050	Pipe shoe MP-PS M4-2 605-615 24" OC	13.83	6.43	32.50	17.29

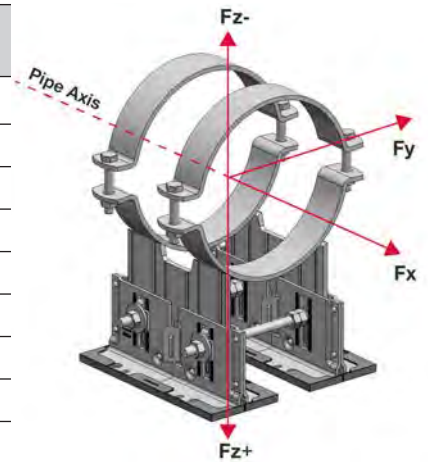
Notes

Shown load data is applicable for pipe shoes without considering the load capacity of the sub-structure and base material.

Interaction formula

$$\left(\frac{F_{x,exp}}{F_{x,rec}}\right)^2 + \left(\frac{F_{y,exp}}{F_{y,rec}}\right)^2 + \left(\frac{F_{z,exp}}{F_{z,rec}}\right)^2 + \frac{F_{x,exp}}{F_{x,rec}} * \frac{F_{y,exp}}{F_{y,rec}} + \frac{F_{x,exp}}{F_{x,rec}} * \frac{F_{z,exp}}{F_{z,rec}} + \frac{F_{y,exp}}{F_{y,rec}} * \frac{F_{z,exp}}{F_{z,rec}} \leq 1.0$$

Recommended loads per EN1993-1-1

Item No.	Pipe Shoe version	+/-F _{x,rec} [kN]	+/-F _{y,rec} [kN]	+/-F _{y,rec} [kN] in combi- nation with X-BT only	+F _{z,rec} [kN]	-F _{z,rec} [kN]	-F _{z,rec} [kN] in combi- nation with X-BT only
2331042	Pipe shoe MP-PS M4-2 217-227 8" OC	33.20	21.33	11.26	36.40	30.74	29.63
2331043	Pipe shoe MP-PS M4-2 244-254 OC	33.20	20.13	10.77	36.40	30.74	29.63
2331044	Pipe shoe MP-PS M4-2 267-277 10" OC	33.20	19.33	10.43	36.40	30.74	29.63
2331045	Pipe shoe MP-PS M4-2 318-328 12" OC	33.20	17.75	9.75	36.40	30.74	29.63
2331046	Pipe shoe MP-PS M4-2 350-360 14" OC	33.20	16.91	9.37	36.40	30.74	29.63
2331047	Pipe shoe MP-PS M4-2 401-411 16" OC	33.20	15.69	8.82	36.40	30.74	29.63
2331048	Pipe shoe MP-PS M4-2 452-462 18" OC	33.20	14.63	8.33	36.40	30.74	29.63
2331049	Pipe shoe MP-PS M4-2 503-513 20" OC	33.20	13.71	7.90	36.40	30.74	29.63
2331050	Pipe shoe MP-PS M4-2 605-615 24" OC	33.20	12.17	7.14	36.40	30.74	29.63

Notes

Shown EN1993-1-1 load values are recommended values with partial safety factors for action and resistance included. Design value in X & Y directions = 1.0 x recommended value. Design value in Z direction = 1.35 x recommended value.

MT-TFB OC and Hex M10 8.8 bolts and X-BT-MR M10/W10: partial safety factors on reaction side of 1.0 in X and Y directions and 1.35 in Z direction

HST3: no edge distance and spacing influence, minimum base material thickness considered, cracked concrete C 20/25, f_{ck,cube}=25 N/mm², partial safety factors on reaction side of 1.0 in X and Y directions and 1.35 in Z direction.

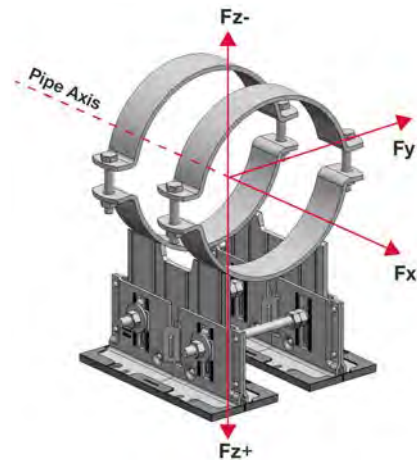
Interaction formula

$$\frac{F_{x,exp}}{F_{x,rec}} + \frac{F_{y,exp}}{F_{y,rec}} + \frac{F_{z,exp}}{F_{z,rec}} \leq 1.0$$

PIPE SHOE MP-PS H4-2

General

Media temperature limits: -20 °C to +300 °C

Height adjustability: 171 - 223.5 mm (with sliding plate)
168 - 220.5 mm (without sliding plate)

Slope adjustability: 12° (21%)

Mass per Pipe Shoe version:

Item no.	Pipe Shoe version	Nominal height	DN (mm)	Mass (kg)
2331051	Pipe shoe MP-PS H4-2 217-227 8" OC	200	DN200	12.78
2331052	Pipe shoe MP-PS H4-2 244-254 OC	200	OD244-254	14.02
2331053	Pipe shoe MP-PS H4-2 267-277 10" OC	200	DN250	14.36
2331054	Pipe shoe MP-PS H4-2 318-328 12" OC	200	DN300	15.10
2331055	Pipe shoe MP-PS H4-2 350-360 14" OC	200	DN350	16.71
2331056	Pipe shoe MP-PS H4-2 401-411 16" OC	200	DN400	17.57
2331057	Pipe shoe MP-PS H4-2 452-462 18" OC	200	DN450	18.46
2331058	Pipe shoe MP-PS H4-2 503-513 20" OC	200	DN500	19.37
2331059	Pipe shoe MP-PS H4-2 605-615 24" OC	200	DN600	21.16



Corrosion protection:

Component	Coating system	Zinc thickness, min. local (µm)
Top pipe ring	HDG per ISO 1461	55
Bottom pipe ring and midplate	HDG per ISO 1461	70
Baseplate	Continuously hot-dip Zinc-Magnesium coated per EN 10346	17
Serrated washers	Continuously hot-dip Zinc-Magnesium coated per EN 10346	17
Bolts; Nuts	HDG per ISO 10684	40;45

Material properties:

Component/Material	min. Yield strength	min. Ultimate strength	Modulus of elasticity	Shear modulus
Pipe rings and midplate S235JR (DIN EN10025-2)	$f_y = 235 \frac{N}{mm^2}$	$f_u = 360 \frac{N}{mm^2}$	$E = 210000 \frac{N}{mm^2}$	$G = 80769 \frac{N}{mm^2}$
Baseplate and serrated washer S280GD (EN 10346) POSMAC-C MOD	$f_y = 280 \frac{N}{mm^2}$	$f_u = 360 \frac{N}{mm^2}$	$E = 210000 \frac{N}{mm^2}$	$G = 80769 \frac{N}{mm^2}$
Bolts; Nuts; Threaded rods F Class 8.8 (ISO 898-1); Grade 8 (ISO 898-2)	$f_y = 640 \frac{N}{mm^2}$	$f_u = 800 \frac{N}{mm^2}$	$E = 210000 \frac{N}{mm^2}$	$G = 80769 \frac{N}{mm^2}$
Sliding plates PA66-GF30	Static friction coefficient values: Hot Dip Galvanized mating surface: 0.13 Zinc-Magnesium mating surface: 0.15 Zinc Electrogalvanised mating surface: 0.18			
Values for Modulus of Elasticity and Shear Modulus are according to EN 1993-1-1 and used for all Eurocode calculations Friction coefficient per ASTM D1894-14				

DESIGN LOADING CAPACITY – 3D

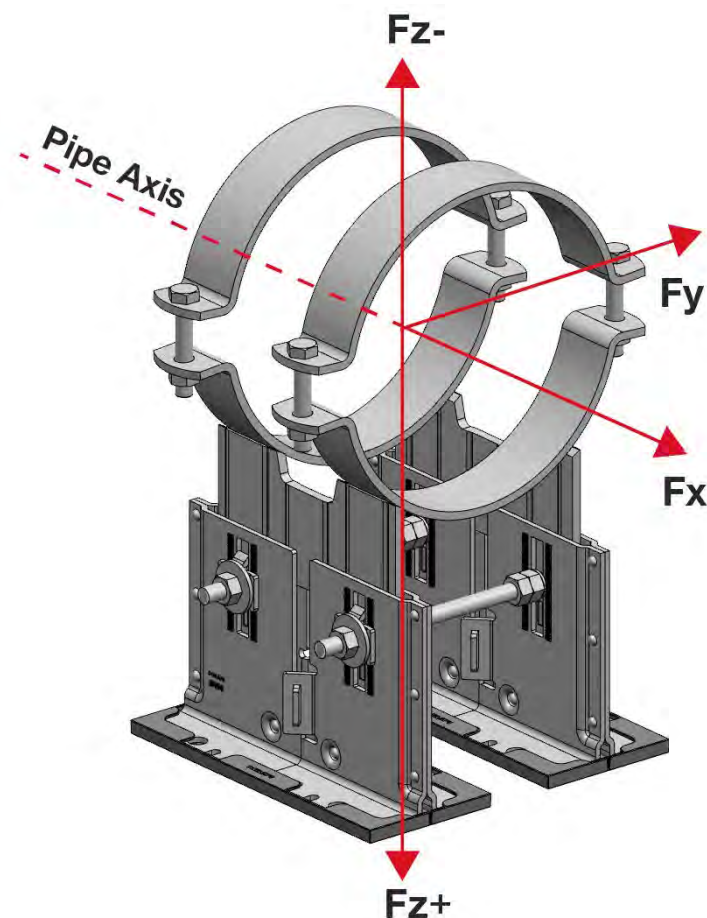
Notes for load data

Load capacity given at delivery height = 200mm BOP (Bottom of pipe).

Point of load application = pipe center line (X-axis).

Load capacity given at room temperature.

Temperature correction factors apply:

- Per VGB-R-510 for load reported acc to EN13480-3

- Per EN 1993-1-2 for loads reported acc to EN1993-1-1

Temperature distribution on pipe shoe components per EN13480-3

Failure locations per force direction:

Fx - deformation of pipe ring

Fy - deformation of baseplate

+Fz, -Fz - ultimate failure at baseplate serrations

Published loads are based on static loading conditions and mounting according to IFU. Non-static forces must be separately considered during design.

Below published load data is applicable for pipe shoes:

- welded to steel according to IFU
- mounted with MT-TFB OC bolts on MT girders
- mounted with Hex M10 8.8 class bolts on I-beams
- mounted with HST3 Stud Anchors
- mounted with X-BT/ F-BT threaded stud

In case of mounting, following configuration has been considered for load data in combination with the closest holes to the center of gravity:

Pipe shoe configuration	Number of fixation elements, pcs
1-1	2
2-2	4
4-2	8

For all other required loads (i.e. different height, -slope,...) please use Fixpoint Calculator

Recommended loads per EN13480-3

Item No.	Pipe Shoe version	+/-F _{x,rec} [kN]	+/-F _{y,rec} [kN]	+F _{z,rec} [kN]	-F _{z,rec} [kN]
2331051	Pipe shoe MP-PS H4-2 217-227 8" OC	13.83	9.45	32.50	17.29
2331052	Pipe shoe MP-PS H4-2 244-254 OC	13.83	9.00	32.50	17.29
2331053	Pipe shoe MP-PS H4-2 267-277 10" OC	13.83	8.69	32.50	17.29
2331054	Pipe shoe MP-PS H4-2 318-328 12" OC	13.83	8.08	32.50	17.29
2331055	Pipe shoe MP-PS H4-2 350-360 14" OC	13.83	7.75	32.50	17.29
2331056	Pipe shoe MP-PS H4-2 401-411 16" OC	13.83	7.26	32.50	17.29
2331057	Pipe shoe MP-PS H4-2 452-462 18" OC	13.83	6.83	32.50	17.29
2331058	Pipe shoe MP-PS H4-2 503-513 20" OC	13.83	6.44	32.50	17.29
2331059	Pipe shoe MP-PS H4-2 605-615 24" OC	13.83	5.79	32.50	17.29

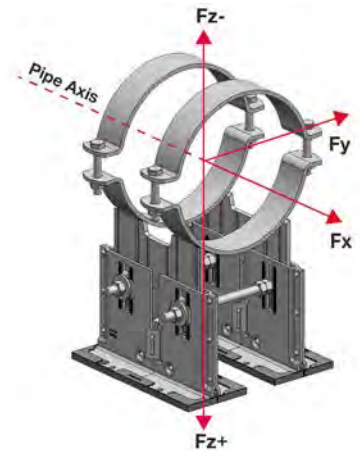
Notes

Shown load data is applicable for pipe shoes without considering the load capacity of the sub-structure and base material.

Interaction formula

$$\left(\frac{F_{x,exp}}{F_{x,rec}}\right)^2 + \left(\frac{F_{y,exp}}{F_{y,rec}}\right)^2 + \left(\frac{F_{z,exp}}{F_{z,rec}}\right)^2 + \frac{F_{x,exp}}{F_{x,rec}} * \frac{F_{y,exp}}{F_{y,rec}} + \frac{F_{x,exp}}{F_{x,rec}} * \frac{F_{z,exp}}{F_{z,rec}} + \frac{F_{y,exp}}{F_{y,rec}} * \frac{F_{z,exp}}{F_{z,rec}} \leq 1.0$$

Recommended loads per EN1993-1-1

Item No.	Pipe Shoe version	+/-F _{x,rec} [kN]	+/-F _{y,rec} [kN]	+/-F _{y,rec} [kN] in combi- nation with X-BT only	+F _{z,rec} [kN]	-F _{z,rec} [kN]	-F _{z,rec} [kN] in combi- nation with X-BT only
2331051	Pipe shoe MP-PS H4-2 217-227 8" OC	33.20	17.89	9.81	36.40	30.74	29.63
2331052	Pipe shoe MP-PS H4-2 244-254 OC	33.20	17.04	9.44	36.40	30.74	29.63
2331053	Pipe shoe MP-PS H4-2 267-277 10" OC	33.20	16.46	9.17	36.40	30.74	29.63
2331054	Pipe shoe MP-PS H4-2 318-328 12" OC	33.20	15.30	8.65	36.40	30.74	29.63
2331055	Pipe shoe MP-PS H4-2 350-360 14" OC	33.20	14.67	8.35	36.40	30.74	29.63
2331056	Pipe shoe MP-PS H4-2 401-411 16" OC	33.20	13.74	7.91	36.40	30.74	29.63
2331057	Pipe shoe MP-PS H4-2 452-462 18" OC	33.20	12.92	7.51	36.40	30.74	29.63
2331058	Pipe shoe MP-PS H4-2 503-513 20" OC	33.20	12.20	7.16	36.40	30.74	29.63
2331059	Pipe shoe MP-PS H4-2 605-615 24" OC	33.20	10.96	6.53	36.40	30.74	29.63

Notes

Shown EN1993-1-1 load values are recommended values with partial safety factors for action and resistance included. Design value in X & Y directions = 1.0 x recommended value. Design value in Z direction = 1.35 x recommended value.

MT-TFB OC and Hex M10 8.8 bolts and X-BT-MR M10/W10: partial safety factors on reaction side of 1.0 in X and Y directions and 1.35 in Z direction

HST3: no edge distance and spacing influence, minimum base material thickness considered, cracked concrete C 20/25, f_{ck,cube}=25 N/mm², partial safety factors on reaction side of 1.0 in X and Y directions and 1.35 in Z direction.

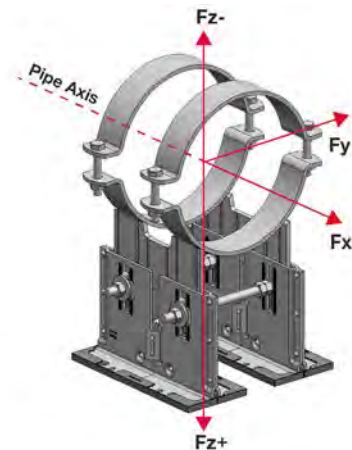
Interaction formula

$$\frac{F_{x,exp}}{F_{x,rec}} + \frac{F_{y,exp}}{F_{y,rec}} + \frac{F_{z,exp}}{F_{z,rec}} \leq 1.0$$

PIPE SHOES CLAMP ORIENTATION

Pipe shoe configuration		1-1			2-2			4-2		
Baseplate size		L	M	H	L	M	H	L	M	H
Range mm inch	NPS mm inch									
		horizontal	50 degrees		horizontal	50 degrees		horizontal	50 degrees	
21-26 mm (0.83 - 1.02 in)	15 mm (1/2 in)	2330922	2330938	2330954	2330973	2330994	2331012			
26-31 mm (1.02 - 1.22 in)	20 mm (3/4 in)	2330923	2330939	2330955	2330974	2330995	2331013			
32-37 mm (1.26 - 1.46 in)	25 mm (1 in)	2330924	2330940	2330956	2330975	2330996	2331014			
38-44 mm (1.50 - 1.73 in)	32 mm (1-1/4 in)	2330925	2330941	2330957	2330976	2330997	2331015			
45-51 mm (1.77 - 2.01 in)	40 mm (1-1/2 in)	2330926	2330942	2330958	2330977	2330998	2331016			
52-58 mm (2.05 - 2.28 in)	-	2330927	2330943	2330959	2330978	2330970	2331017			
59-65 mm (2.32 - 2.56 in)	50 mm (2 in)	2330928	2330944	2330960	2330979	2330971	2331018			
68-74mm (2.68 - 2.91 in)	-	2330929	2330945	2330961	2330980	2330972	2331019			
75-81 mm (2.95 - 3.19 in)	65 mm (2-1/2 in)	2330930	2330946	2330962	2330981	2330999	2331020			
88-94 mm (3.46 - 3.70 in)	80 mm (3 in)	2330931	2330947	2330963	2330982	2331000	2331021			
100-108 mm (3.94 - 4.25 in)	- (3-1/2 in)	2330932	2330948	2330964	2330983	2331001	2331022			
110-118 mm (4.33 - 4.65 in)	100 mm (4 in)	2330933	2330949	2330965	2330984	2331002	2331023			
125-133 mm (4.92 - 5.24 in)	-	2330934	2330950	2330966	2330985	2331003	2331024			
136-144 mm (5.35 - 5.67 in)	125 mm (5 in)	2330935	2330951	2330967	2330986	2331004	2331025			
152-162 mm (5.98 - 6.38 in)	-	2330936	2330952	2330968	2330987	2331005	2331026			
163-173 mm (6.42 - 6.81 in)	150 mm (6 in)	2330937	2330953	2330969	2330988	2331006	2331027			
192-202 mm (7.56 - 7.95 in)	-				2330989	2331007	2331028			
217-227 mm (8.54 - 8.94 in)	200 mm (8 in)				2330990	2331008	2331029	2331033	2331042	2331051
244-254 mm (9.61 - 10.00 in)	-				2330991	2331009	2331030	2331034	2331043	2331052
267-277 mm (10.51 - 10.91 in)	250 mm (10 in)				2330992	2331010	2331031	2331035	2331044	2331053
318-328 mm (12.52 - 12.91 in)	300 mm (12 in)				2330993	2331011	2331032	2331036	2331045	2331054
350-360 mm (13.78 - 14.17 in)	350 mm (14 in)							2331037	2331046	2331055
401-411 mm (15.79 - 16.18 in)	400 mm (16 in)							2331038	2331047	2331056
452-462 mm (17.80 - 18.19 in)	450 mm (18 in)							2331039	2331048	2331057
503-513 mm (19.80 - 20.20 in)	500 mm (20 in)							2331040	2331049	2331058
605-615 mm (23.82 - 24.21 in)	600 mm (24 in)							2331041	2331050	2331059

PIPE SHOE MP-PS M2-W

Adjustable and weldable pipe shoes with outdoor coating (HDG) for fastening 1/2" to 12" (21 mm to 328 mm) diameter pipes to various base materials in moderately corrosive environments.



MP-PS M-BP OC



MP-PS M2-W NC



MP-PS SP-2

Material Properties^{1,2}

Component	Type	Material (Reference)	F _y Yield strength N/mm ²	F _t Tensile strength N/mm ²	E Modulus of elasticity N/mm ²	G Shear modulus N/mm ²
MP-PS M-BP OC	Baseplate	S280GD (EN1034)	280	360	210000	80769
MP-PS M2-W NC ²	Weldable mid-plate	S235JR (DIN EN 10025-2)	280	360	210000	80769
MP-PS SP-2	Sliding plate	Static friction coefficient values per ASTM D1894-14 Hot Dip Galvanized mating surface: 0.13 Zinc-Magnesium ating surface: 0.15 Zinc plated mating surface: 0.18				

¹ Capacities provided for the components are based on each product at an assumed room temperature of 20°C (68°F).

² Weldable mid-plate is uncoated.

Pipe Shoe MP-PS M2-W Ordering Information

Order description	Weight per piece	Box quantity	Item number
MP-PS M2-WS NC	3.28 kg (7.23 lb)	4 pc	2381683
MP-PS M2-WF NC	3.14 kg (6.92 lb)	4 pc	2381684

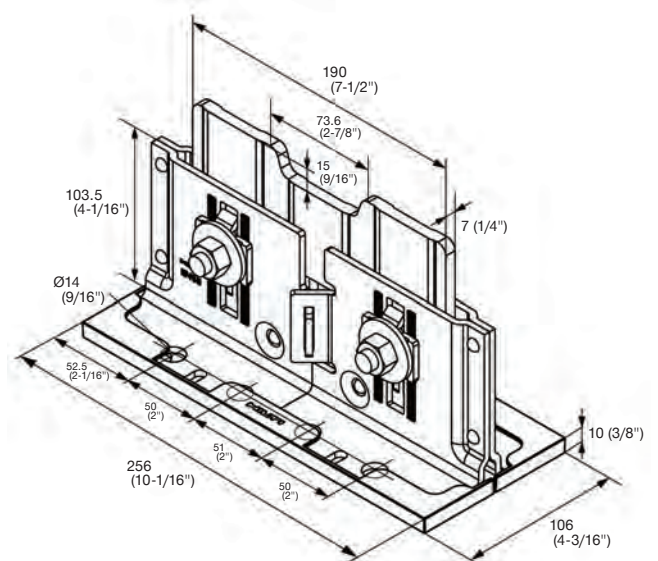
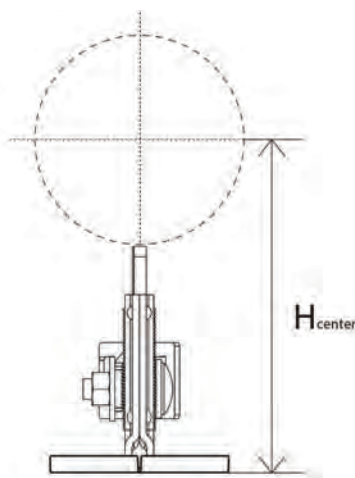

PIPE SHOE MP-PS M2-W TECHNICAL DATA

Allowable Loading per EN13480-3 ^{1,2,3,4}

H Center in. (mm)	+/-Fx (kN)	+/-Fy (kN)	+Fz (kN)	-Fz (kN)
< 250 mm (< 9.84 in)	$(48.5 \cdot H_{\text{center}} + 6400)/1000$	387.6/ H_{center}	17.57	13.44
< 250 mm (< 9.84 in)	18.58			

¹ Tabulated directional values apply separately in each direction. A combination of loads must be considered separately, and an appropriate interaction equation defined by the Design Professional must be used.

² Tabulated values as shown do not include or account for anchorage. Anchorage must be determined separately and may reduce the overall capacity from the tabulated values.

³ Selection of the welding process, welding addition, design of the weld size as well as welding preparation and execution are the responsibility of the customer.

⁴ H_{center} units are in millimeters.

Allowable Loading per EC 3 ^{1,2,3,4}

H Center in. (mm)	+/-Fx (kN)	+/-Fy (kN)	+Fz (kN)	-Fz (kN)
< 250 mm (< 9.84 in)	$(69.9 \cdot H_{\text{center}} + 9216)/1000$	393.9/ H_{center}	19.76	15.20
< 250 mm (< 9.84 in)	26.48			

¹ Tabulated directional values apply separately in each direction. A combination of loads must be considered separately, and an appropriate interaction equation defined by the Design Professional must be used.

² Tabulated values as shown do not include or account for anchorage. Anchorage must be determined separately and may reduce the overall capacity from the tabulated values.

³ Selection of the welding process, welding addition, design of the weld size as well as welding preparation and execution are the responsibility of the customer.

⁴ H_{center} units are in millimeters.

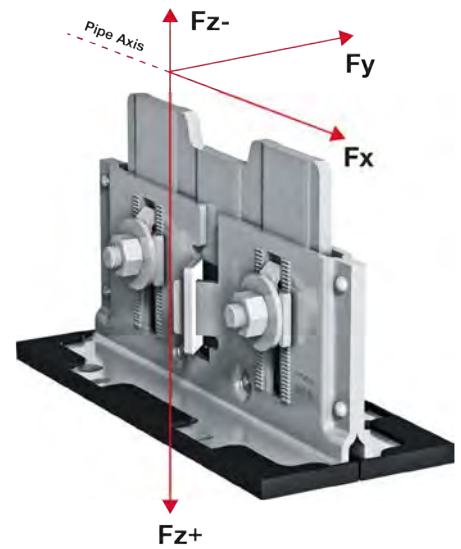

EPDM-INSULATING BAND MP-A I-R

For adding galvanic separation and mild acoustic isolation to MP-PS pipe shoes.



APPLICATIONS

- Creating temperature separation between pipes and pipe clamps to reduce temperature transfer to sub-structure
- Creating surface separation between pipes and pipe clamps to prevent direct contact between different materials

ADVANTAGES

- Galvanic separation — helps prevent direct contact between pipe clamp and pipe (helping to avoid acoustic bridging)
- Adaptable — suitable for all MP-PS pipe shoes due to the clamping range of the pipe clamps (no specific clamp diameter required)

Product Information

Material composition	EPDM + self-adhesive layer + release liner
Material composition details	<ul style="list-style-type: none"> • EPDM (ASTM D2240) • Shore A 66° ± 75° • Tensile strength min. 0.73 ksi (5 MPa)
Friction coefficient (steel pipe vs. inlay)	<ul style="list-style-type: none"> • Static: min. 0.3 • Kinetic: min. 0.3
Environmental conditions	Outdoor, low to moderate pollution (C3)
Temperature resistance (based on EN13480-3)	-20 °C to 100 °C (-4 °F to 212 °F)
Fire resistance (Yes/No)	No

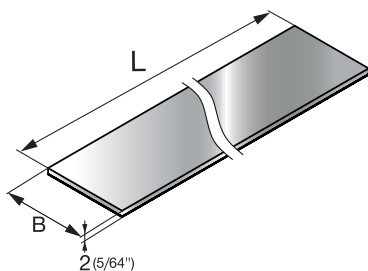

Order Designation	Cross Section Width	Thick-ness	Length	Fits to MP-PS pipe shoes (nominal sizes)	Using one size wider inlay fits to MP-PS pipe shoes	Sales qty	Item number
MP-A I-R 30/2/5	30 mm (1.18 in)	2 mm (0.08 in)	5 m (16.40 ft)	1/2" - 1-1/2"	-	1 pcs	2331060
MP-A I-R 40/2/10	40 mm (1.57 in)	2 mm (0.08 in)	10 m (32.80 ft)	2" - 6"	1/2" - 1-1/2"	1 pcs	2331061
MP-A I-R 50/2/26	50 mm (1.97 in)	2 mm (0.08 in)	26 m (85.30 ft)	7" - 12"	2" - 6"	1 pcs	2331062
MP-A I-R 60/2/26	60 mm (2.36 in)	2 mm (0.08 in)	26 m (85.30 ft)	14" - 24"	7" - 12"	1 pcs	2331063

SILICONE-INSULATING BAND MP-A I-S

For adding galvanic separation and mild acoustic isolation to MP-PS pipe shoes.



APPLICATIONS

- Creating temperature separation between pipes and pipe clamps to reduce temperature transfer to sub-structure
- Creating surface separation between pipes and pipe clamps to prevent direct contact between different materials

ADVANTAGES

- Galvanic separation — helps prevent direct contact between pipe clamp and pipe (helping to avoid acoustic bridging)
- Adaptable — suitable for all MP-PS pipe shoes due to the clamping range of the pipe clamps (no specific clamp diameter required)

Product Information

Material composition	Silikon + self-adhesive layer + release liner
Material composition details	<ul style="list-style-type: none"> • Silikon — elastosil R 401/60 S • Shore A 60°±5° • Density 71.79 lb/ft³ (1150 kg/m³) • Tensile strength 1.60 ksi (11MPa)
Friction coefficient (steel pipe vs. inlay)	<ul style="list-style-type: none"> • Static: min. 0.3 • Kinetic: min. 0.3
Environmental conditions	Outdoor, low to moderate pollution (C3)
Temperature resistance (based on EN13480-3)	-20 °C to 210 °C (4 °F to 410 °F)
Fire resistance (Yes/No)	No

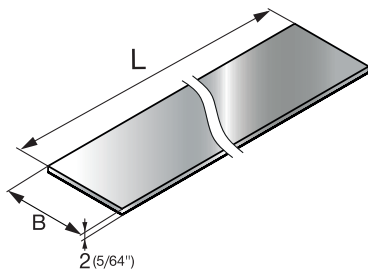

Order Designation	Cross Section Width	Thick-ness	Length	Fits to MP-PS pipe shoes (nominal sizes)	Using one size wider inlay fits to MP-PS pipe shoes	Sales qty	Item number
MP-A I-S 30/2/5	30 mm (1.18 in)	2 mm (0.08 in)	5 m (16.40 ft)	1/2" - 1-1/2"	-	1 pcs	2331064
MP-A I-S 40/2/10	40 mm (1.57 in)	2 mm (0.08 in)	10 m (32.80 ft)	2" - 6"	1/2" - 1-1/2"	1 pcs	2331065
MP-A I-S 50/2/26	50 mm (1.97 in)	2 mm (0.08 in)	26 m (85.30 ft)	7" - 12"	2" - 6"	1 pcs	2331066
MP-A I-S 60/2/26	60 mm (2.36 in)	2 mm (0.08 in)	26 m (85.30 ft)	14" - 24"	7" - 12"	1 pcs	2331067

GLASS FIBER-INSULATING BAND MP-A I-GF

For adding galvanic separation to MP-PS pipe shoes.



APPLICATIONS

- Creating temperature separation between pipes and pipe clamps to reduce temperature transfer to sub-structure
- Creating surface separation between pipes and pipe clamps to prevent direct contact between different materials

ADVANTAGES

- Galvanic separation — helps prevent direct contact between pipe clamp and pipe (helping to avoid acoustic bridging)
- Adaptable — suitable for all MP-PS pipe shoes due to the clamping range of the pipe clamps (no specific clamp diameter required)

Product Information

Material composition	Texturized E-Glass fiber + self-adhesive layer + release liner
Material composition details	<ul style="list-style-type: none"> • Glass used E type • Fiber diameter 9 µm
Friction coefficient (steel pipe vs. inlay)	-
Environmental conditions	Outdoor, low to moderate pollution (C3)
Temperature resistance (based on EN13480-3)	-20 °C to 500 °C (-4 °F to 932 °F)
Fire resistance (Yes/No)	No

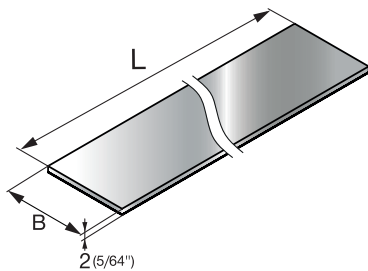

Order Designation	Cross Section Width	Thick-ness	Length	Fits to MP-PS pipe shoes (nominal sizes)	Using one size wider inlay fits to MP-PS pipe shoes	Sales qty	Item number
MP-A I-GF 30/2/5	30 mm (1.18 in)	2 mm (0.08 in)	5 m (16.40 ft)	1/2" - 1-1/2"	-	1 pcs	2331068
MP-A I-GF 40/2/5	40 mm (1.57 in)	2 mm (0.08 in)	5 m (16.40 ft)	2" - 6"	1/2" - 1-1/2"	1 pcs	2331069
MP-A I-GF 50/2/25	50 mm (1.97 in)	2 mm (0.08 in)	25 m (82 ft)	7" - 12"	2" - 6"	1 pcs	2331070
MP-A I-GF 60/2/25	60 mm (2.36 in)	2 mm (0.08 in)	25 m (82 ft)	14" - 24"	7" - 12"	1 pcs	2331071

INSULATING BANDS DATA SHEET

item #	Name	Cross Section Width mm (inch)	Thickness mm (inch)	Length m (ft)	Material composition	Material composition details	Friction coefficient (steel pipe vs inlay)	Fx,rec axial force (without welded stop) according to grip force [kN]*			Fire resistance (Yes/No)	min. Temperature resistance - °C (°F)	max Temperature resistance - °C (°F)	fits to MP-PS pipe shoes (nominal sizes)	using one size wider inlay fits to MP-PS pipe shoes				
								1-1	2-2	4-2									
2331060	Insulating band MP-A I-R 30/2/5	30 (1.18)	2 (0.08)	5 (16)	EPDM + self-adhesive layer +release liner	EPDM (ASTM D2240) Shore A 66° ÷ 75° Tensile strength min. 5 MPa	Static: min 0.3 Kinetic: min. 0.3	0	0.49	/	No	-20 (-4)	100 (212)	1/2" - 1 1/2"	N/A				
2331061	Insulating band MP-A I-R 40/2/10	40 (1.57)	2 (0.08)	10 (33)				0	0.49	/						-20 (-4)	100 (212)	2" - 6"	1/2" - 1 1/2"
2331062	Insulating band MP-A I-R 50/2/26	50 (1.97)	2 (0.08)	26 (85)				/	0.49	1									
2331063	Insulating band MP-A I-R 60/2/26	60 (2.36)	2 (0.08)	26 (85)				/	/	1						-20 (-4)	100 (212)	14" - 24"	7" - 12"
2331064	Insulating band MP-A I-S 30/2/5	30 (1.18)	2 (0.08)	5 (16)	Silicone + self-adhesive layer +release liner	Silicone - elastosil R 401/60 S Shore A 60°±5° Density 1150 kg/m3 Tensile strength 11 MPa	Static: min 0.3 Kinetic: min. 0.3	0	0	/	No	-20 (-4)	210 (410)	1/2" - 1 1/2"	N/A				
2331065	Insulating band MP-A I-S 40/2/10	40 (1.57)	2 (0.08)	10 (33)				0	0	/						-20 (-4)	210 (410)	2" - 6"	1/2" - 1 1/2"
2331066	Insulating band MP-A I-S 50/2/26	50 (1.97)	2 (0.08)	26 (85)				/	0	1									
2331067	Insulating band MP-A I-S 60/2/26	60 (2.36)	2 (0.08)	26 (85)				/	/	1						-20 (-4)	210 (410)	14" - 24"	7" - 12"
2331068	Insulating band MP-A I-GF 30/2/5	30 (1.18)	2 (0.08)	5 (16)	Texturized E-Glass fiber + self-adhesive layer	Glass used E type Fiber diameter 9 µm	N.A	0	1	/	No	-20 (-4)	500 (932)	1/2" - 1 1/2"	N/A				
2331069	Insulating band MP-A I-GF 40/2/5	40 (1.57)	2 (0.08)	5 (16)				0	1	/						-20 (-4)	500 (932)	2" - 6"	1/2" - 1 1/2"
2331070	Insulating band MP-A I-GF 50/2/25	50 (1.97)	2 (0.08)	25 (82)				/	1	1									
2331071	Insulating band MP-A I-GF 60/2/25	60 (2.36)	2 (0.08)	25 (82)				/	/	1						-20 (-4)	500 (932)	14" - 24"	7" - 12"

Remarks: *

FX,rec are Recommended axial force values established by test according to Annex D of EN 1993:2002/A1:2005 with 1,35 safety factor included on resistance side.

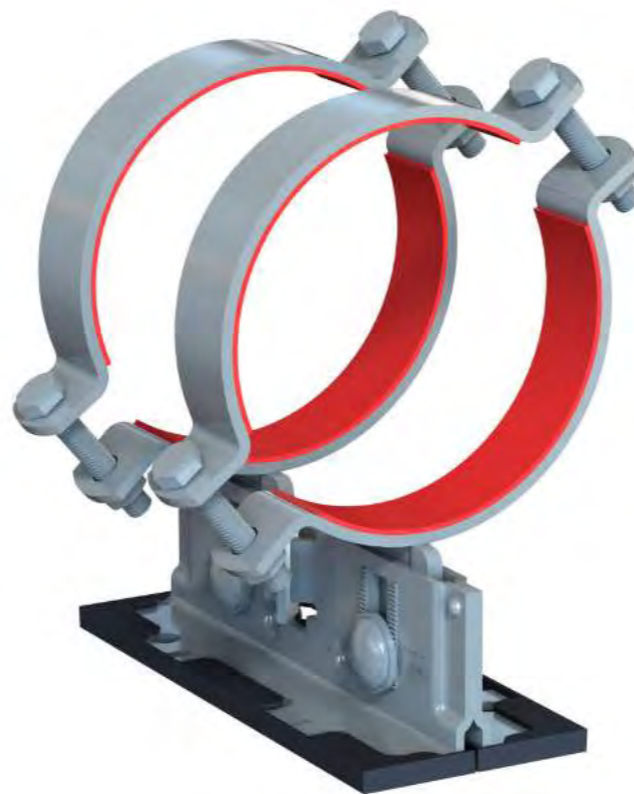

MT-FPS-FF OC

Item no.	Material Description
2331076	Connector Pipe shoe MT-FPS-FF OC

Material properties:

Component/Material	min. Yield strength	min. Ultimate strength	Modulus of elasticity	Shear modulus
S280GD (EN 10346)	$f_y = 280 \frac{\text{N}}{\text{mm}^2}$	$f_u = 360 \frac{\text{N}}{\text{mm}^2}$	$E = 210000 \frac{\text{N}}{\text{mm}^2}$	$G = 80769 \frac{\text{N}}{\text{mm}^2}$

Values for Modulus of Elasticity and Shear Modulus are according to EN 1993-1-1 and used for all Eurocode calculations

General

- Media temperature limits: -20 °C to +300 °C
- Mass per single item: 0.275kg
- Continuously hot-dip Zinc-Magnesium coated per EN 10346

DESIGN LOADING CAPACITY – 3D

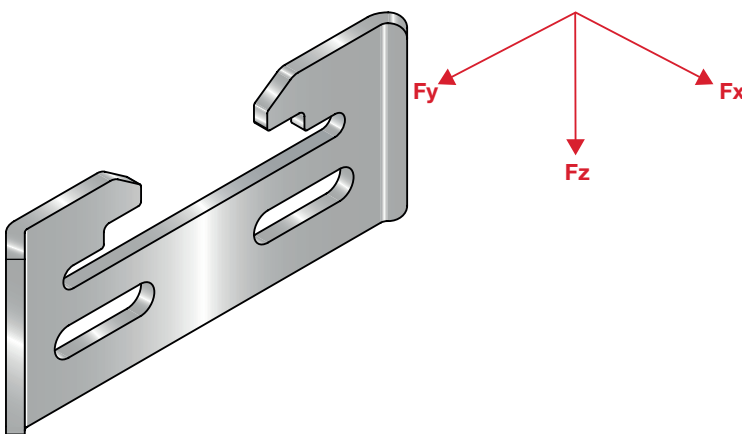

Notes for load data

Point of load application = pipe center line (X-axis). Load data per configuration (2 items or 4 items) of the brackets installed with MP-PS x1-1, MP-PS x2-2, or MP-PS x4-2 according to IFU. Load capacity given at room temperature. Temperature correction factors apply:

- Per VGB-R-510 for load reported acc to EN13480-3
- Per EN 1993-1-2 for loads reported acc to EN1993-1-1

Temperature distribution on pipe shoe components per EN13480-3. Published loads are based on static loading conditions. Non-static forces must be separately considered during design.

Recommended loads per EN13480-3

Configuration	+/-F _{x,rec} [kN]	+/-F _{y,rec} [kN]	+F _{z,rec} [kN]	-F _{z,rec} [kN]
2 brackets	7.43	227.73/h*	not decisive	6.31
4 brackets	14.86	871.53/h*	not decisive	12.62

*h – Height of pipe neutral axis in mm from pipe shoe base

Recommended loads per EN1993-1-1⁽²⁾

Configuration	+/-F _{x,rec} [kN]	+/-F _{y,rec} [kN]	+F _{z,rec} [kN]	-F _{z,rec} [kN]
2 brackets	16.39	471.23/h*	not decisive	10.98
4 brackets	32.78	1803.40/h*	not decisive	21.96

*h – Height of pipe neutral axis in mm from pipe shoe base

(2) Notes

Shown EN1993-1-1 load values are recommended values with partial safety factors for action and resistance included. Design value in X & Y directions = 1.0 x recommended value. Design value in Z direction = 1.35 x recommended value.

Interaction formula

$$\frac{F_{x,exp}}{F_{x,rec}} + \frac{F_{y,exp}}{F_{y,rec}} + \frac{F_{z,exp}}{F_{z,rec}} \leq 1.0$$

MT-FPS-FZL OC

Item no.	Material Description
2331077	Connector Pipe shoe MT-FPS-FZL OC

General

- Media temperature limits: -20 °C to +300 °C
- Mass per single item: 0.583 kg
- HDG: 55µm minimum local thickness - ISO 1461

Material properties:

Component/Material	min. Yield strength	min. Ultimate strength	Modulus of elasticity	Shear modulus
S235JR (DIN EN 10025-2)	$f_y = 235 \frac{\text{N}}{\text{mm}^2}$	$f_u = 360 \frac{\text{N}}{\text{mm}^2}$	$E = 210000 \frac{\text{N}}{\text{mm}^2}$	$G = 80769 \frac{\text{N}}{\text{mm}^2}$

Values for Modulus of Elasticity and Shear Modulus are according to EN 1993-1-1 and used for all Eurocode calculations

DESIGN LOADING CAPACITY – 3D

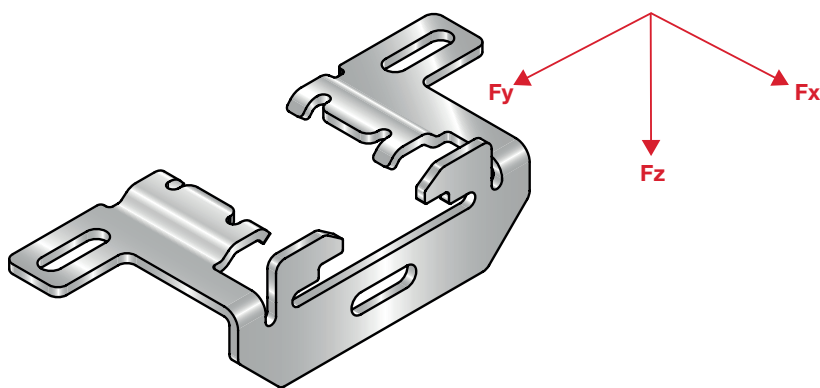

Notes for load data

Point of load application = pipe center line (X-axis). Load capacity given at room temperature. Temperature correction factors apply:

- Per VGB-R-510 for load reported acc to EN13480-3
- Per EN 1993-1-2 for loads reported acc to EN1993-1-1

Temperature distribution on pipe shoe components per EN13480-3
Published loads are based on static loading conditions. Non-static forces must be separately considered during design.

Recommended loads per EN13480-3

$\pm F_{x,rec}$ [kN]	$\pm F_{y,rec}$ [kN]	$+F_{z,rec}$ [kN]	$-F_{z,rec}$ [kN]
9.23	243.37/h*	not decisive	3.53

*h – Height of pipe neutral axis in mm from pipe shoe base

Recommended loads per EN1993-1-1 ⁽²⁾

$\pm F_{x,rec}$ [kN]	$\pm F_{y,rec}$ [kN]	$+F_{z,rec}$ [kN]	$-F_{z,rec}$ [kN]
18.84	450.00/h*	not decisive	6.87

*h – Height of pipe neutral axis in mm from pipe shoe base

⁽²⁾ Notes

Shown EN1993-1-1 load values are recommended values with partial safety factors for action and resistance included. Design value in X & Y directions = 1.0 x recommended value. Design value in Z direction = 1.35 x recommended value.

Interaction formula

$$\frac{F_{x,exp}}{F_{x,rec}} + \frac{F_{y,exp}}{F_{y,rec}} + \frac{F_{z,exp}}{F_{z,rec}} \leq 1.0$$

MT-FPS-SF OC

Item no.	Material Description
2330920	Connector Pipe shoe MT-FPS-SF OC

General

- Media temperature limits: -20 °C to +300 °C
- Mass per single item: 0.273 kg
- Continuously hot-dip Zinc-Magnesium coated per EN 10346

Material properties:

Component/Material	min. Yield strength	min. Ultimate strength	Modulus of elasticity	Shear modulus
S280GD (EN10346)	$f_y = 280 \frac{\text{N}}{\text{mm}^2}$	$f_u = 360 \frac{\text{N}}{\text{mm}^2}$	$E = 210000 \frac{\text{N}}{\text{mm}^2}$	$G = 80769 \frac{\text{N}}{\text{mm}^2}$

Values for Modulus of Elasticity and Shear Modulus are according to EN 1993-1-1 and used for all Eurocode calculations

DESIGN LOADING CAPACITY – 3D

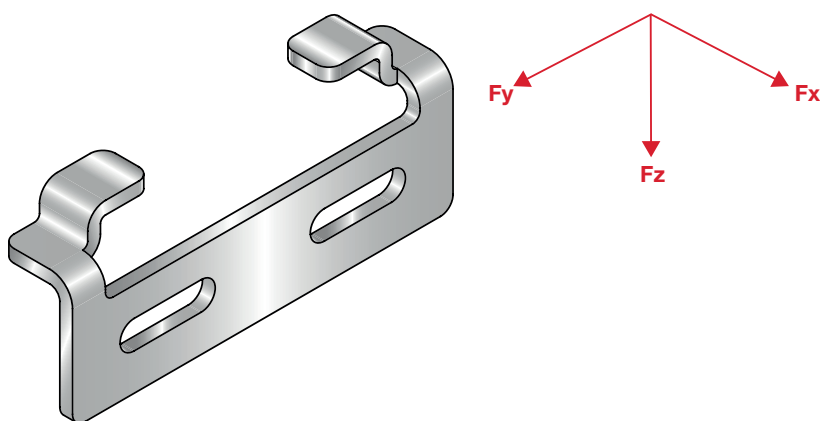

Notes for load data

Point of load application = pipe center line (X-axis). Load data per configuration (2 items or 4 items) of the brackets installed with MP-PS x1-1, MP-PS x2-2, or MP-PS x4-2 according to IFU.

Load capacity given at room temperature. Temperature correction factors apply:

- Per VGB-R-510 for load reported acc to EN13480-3
- Per EN 1993-1-2 for loads reported acc to EN1993-1-1

Temperature distribution on pipe shoe components per EN13480-3

Published loads are based on static loading conditions. Non-static forces must be separately considered during design.

Recommended loads per EN13480-3

Configuration	+/- $F_{x,rec}$ [kN]	+/- $F_{y,rec}$ [kN]	+ $F_{z,rec}$ [kN]	- $F_{z,rec}$ [kN]
2 brackets	not decisive	138.30/h*	not decisive	3.10
4 brackets	not decisive	529.30/h*	not decisive	6.20

*h – Height of pipe neutral axis in mm from pipe shoe base

Recommended loads per EN1993-1-1⁽²⁾

Configuration	+/- $F_{x,rec}$ [kN]	+/- $F_{y,rec}$ [kN]	+ $F_{z,rec}$ [kN]	- $F_{z,rec}$ [kN]
2 brackets	not decisive	290.80/h*	not decisive	4.96
4 brackets	not decisive	1112.90/h*	not decisive	9.92

*h – Height of pipe neutral axis in mm from pipe shoe base

⁽²⁾Notes

Shown EN1993-1-1 load values are recommended values with partial safety factors for action and resistance included. Design value in Y direction = 1.0 x recommended value. Design value in Z direction = 1.35 x recommended value.

Interaction formula

$$\frac{F_{y,exp}}{F_{y,rec}} + \frac{F_{z,exp}}{F_{z,rec}} \leq 1.0$$

MT-FPS-SZ1 OC

Item no.	Material Description
2331078	Connector Pipe shoe MT-FPS-SZ1 OC

General

- Media temperature limits: -20 °C to +300 °C
- Mass per single item: 0.176 kg
- Continuously hot-dip Zinc-Magnesium coated per EN 10346

Material properties:

Component/Material	min. Yield strength	min. Ultimate strength	Modulus of elasticity	Shear modulus
S280GD (EN 10346)	$f_y = 280 \frac{N}{mm^2}$	$f_u = 360 \frac{N}{mm^2}$	$E = 210000 \frac{N}{mm^2}$	$G = 80769 \frac{N}{mm^2}$

Values for Modulus of Elasticity and Shear Modulus are according to EN 1993-1-1 and used for all Eurocode calculations

DESIGN LOADING CAPACITY – 3D

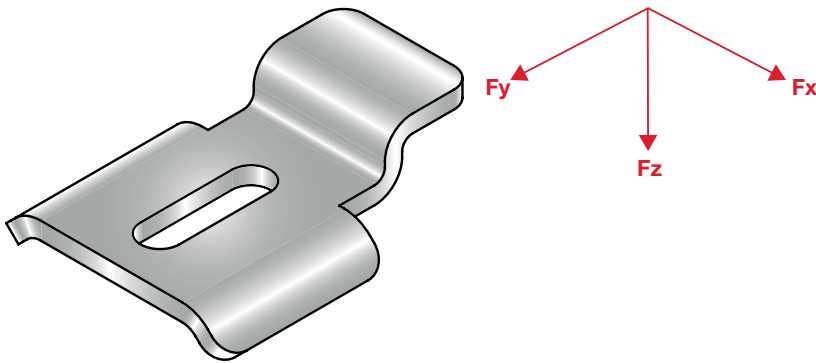

Notes for load data

Point of load application = pipe center line (X-axis). Load data per set (2 items) of the brackets installed with MP-PS x1-1 and MP-PS x2-2 according to IFU. Load capacity given at room temperature. Temperature correction factors apply:

- Per VGB-R-510 for load reported acc to EN13480-3
- Per EN 1993-1-2 for loads reported acc to EN1993-1-1

Temperature distribution on pipe shoe components per EN13480-3
Published loads are based on static loading conditions. Non-static forces must be separately considered during design.

Recommended loads per EN13480-3

$\pm F_x, R_{rec}$ [kN]	$\pm F_y, R_{rec}$ [kN]	$+F_z, R_{rec}$ [kN]	$-F_z, R_{rec}$ [kN]
not decisive	59.30/h*	not decisive	1.29

*h – Height of pipe neutral axis in mm from pipe shoe base

Recommended loads per EN1993-1-1⁽²⁾

$\pm F_x, R_{rec}$ [kN]	$\pm F_y, R_{rec}$ [kN]	$\pm F_y, R_{rec}$ [kN] in combination with X-BT only	$+F_z, R_{rec}$ [kN]	$-F_z, R_{rec}$ [kN]	$-F_z, R_{rec}$ [kN] in combination with X-BT only
not decisive	127.87/h*	53.9/h*	not decisive	2.07	0.80

*h – Height of pipe neutral axis in mm from pipe shoe base

⁽²⁾Notes

Shown EN1993-1-1 load values are recommended values with partial safety factors for action and resistance included. Design value in Y direction = 1.0 x recommended value. Design value in Z direction = 1.35 x recommended value. Shown load values apply for piece parts mounted with MT-TFB and X-BT, respectively.

Interaction formula

$$\frac{F_{y,exp}}{F_{y,rec}} + \frac{F_{z,exp}}{F_{z,rec}} \leq 1.0$$

MT-FPS-SZ2 OC

Item no.	Material Description
2331079	Connector Pipe shoe MT-FPS-SZ2 OC

General

- Media temperature limits: -20 °C to +300 °C
- Mass per single item: 0.254 kg
- Continuously hot-dip Zinc-Magnesium coated per EN 10346

Material properties:

Component/Material	min. Yield strength	min. Ultimate strength	Modulus of elasticity	Shear modulus
S280GD (EN 10346)	$f_y = 280 \frac{N}{mm^2}$	$f_u = 360 \frac{N}{mm^2}$	$E = 210000 \frac{N}{mm^2}$	$G = 80769 \frac{N}{mm^2}$

Values for Modulus of Elasticity and Shear Modulus are according to EN 1993-1-1 and used for all Eurocode calculations

DESIGN LOADING CAPACITY – 3D

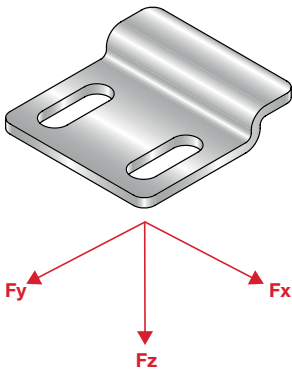

Notes for load data

Point of load application = pipe center line (X-axis)
 Load data per configuration (2 items) of the brackets installed with MP-PS x1-1, MP-PS x2-2, or MP-PS x4-2 according to IFU.
 Load capacity given at room temperature.
 Temperature correction factors apply:
 • Per VGB-R-510 for load reported acc to EN13480-3
 • Per EN 1993-1-2 for loads reported acc to EN1993-1-1
 Temperature distribution on pipe shoe components per EN13480-3
 Published loads are based on static loading conditions. Non-static forces must be separately considered during design

(2)Notes

Shown EN1993-1-1 load values are recommended values with partial safety factors for action and resistance included. Design value in Y direction = 1.0 x recommended value. Design value in Z direction = 1.35 x recommended value.
 Shown load values apply for piece parts mounted with MT-TFB and X-BT, respectively.

Interaction formula

$$\frac{F_{y,exp}}{F_{y,rec}} + \frac{F_{z,exp}}{F_{z,rec}} \leq 1.0$$

Recommended loads per EN13480-3

Configuration	+/-F _{x,rec} [kN]	+/-F _{y,rec} [kN]	+F _{z,rec} [kN]	-F _{z,rec} [kN]
MP-PS x1-1/x2-2	not decisive	84.10/h*	not decisive	1.83
MP-PS x4-2		214.9/h*		

*h – Height of pipe neutral axis in mm from pipe shoe base

Recommended loads per EN1993-1-1⁽²⁾

Configuration	+/-F _{x,rec} [kN]	+/-F _{y,rec} [kN]	+/-F _{y,rec} [kN] (in combination with X-BT)	+F _{z,rec} [kN]	-F _{z,rec} [kN]	-F _{z,rec} [kN] (in combination with X-BT)
MP-PS x1-1/x2-2	not decisive	181.4/h*	76.5/h*	not decisive	2.93	1.14
MP-PS x4-2		463.40/h*	198.6/h*			

*h – Height of pipe neutral axis in mm from pipe shoe base

MT-FPS-GF OC

Item no.	Material Description
2330921	Connector Pipe shoe MT-FPS-GF OC

General

- Media temperature limits: -20 °C to +300 °C
- Mass per single item: 0.298 kg
- Continuously hot-dip Zinc-Magnesium coated per EN 10346

Material properties:

Component/Material	min. Yield strength	min. Ultimate strength	Modulus of elasticity	Shear modulus
S280GD (EN 10346)	$f_y = 280 \frac{\text{N}}{\text{mm}^2}$	$f_u = 360 \frac{\text{N}}{\text{mm}^2}$	$E = 210000 \frac{\text{N}}{\text{mm}^2}$	$G = 80769 \frac{\text{N}}{\text{mm}^2}$

Values for Modulus of Elasticity and Shear Modulus are according to EN 1993-1-1 and used for all Eurocode calculations

DESIGN LOADING CAPACITY – 3D

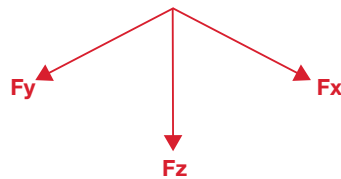
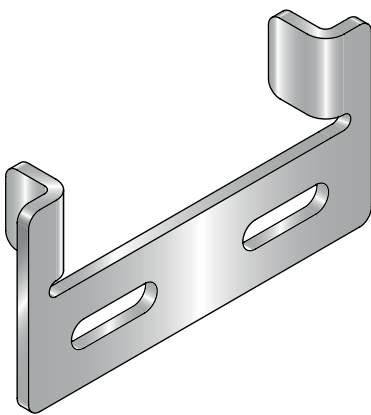

Notes for load data

Point of load application = pipe center line (X-axis). Load data per configuration (2 items or 4 items) of the brackets installed with MP-PS x1-1, MP-PS x2-2, or MP-PS x4-2 according to IFU.

Load capacity given at room temperature. Temperature correction factors apply:

- Per VGB-R-510 for load reported acc to EN13480-3
- Per EN 1993-1-2 for loads reported acc to EN1993-1-1

Temperature distribution on pipe shoe components per EN13480-3

Published loads are based on static loading conditions. Non-static forces must be separately considered during design.

Recommended loads per EN13480-3

Configuration	+/-F _{x,rec} [kN]	+/-F _{y,rec} [kN]	+F _{z,rec} [kN]	-F _{z,rec} [kN]
2 brackets	not decisive	2.33	not decisive	not decisive
4 brackets	not decisive	4.66	not decisive	not decisive

(2)Notes

Shown EN1993-1-1 load values are recommended values with partial safety factors for action and resistance included. Design value in Y direction = 1.0 x recommended value.

Recommended loads per EN1993-1-1⁽²⁾

Configuration	+/-F _{x,rec} [kN]	+/-F _{y,rec} [kN]	+F _{z,rec} [kN]	-F _{z,rec} [kN]
2 brackets	not decisive	4.62	not decisive	not decisive
4 brackets	not decisive	9.24	not decisive	not decisive

MT-FPS-GL1 OC

Item no.	Material Description
2331080	Connector Pipe shoe MT-FPS-GL1 OC

General

- Media temperature limits: -20 °C to +300 °C
- Mass per single item: 0.182 kg
- Continuously hot-dip Zinc-Magnesium coated per EN 10346

Material properties:

Component/Material	min. Yield strength	min. Ultimate strength	Modulus of elasticity	Shear modulus
S280GD (EN 10346)	$f_y = 280 \frac{\text{N}}{\text{mm}^2}$	$f_u = 360 \frac{\text{N}}{\text{mm}^2}$	$E = 210000 \frac{\text{N}}{\text{mm}^2}$	$G = 80769 \frac{\text{N}}{\text{mm}^2}$

Values for Modulus of Elasticity and Shear Modulus are according to EN 1993-1-1 and used for all Eurocode calculations

DESIGN LOADING CAPACITY – 3D

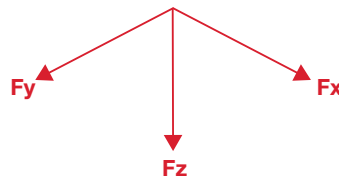
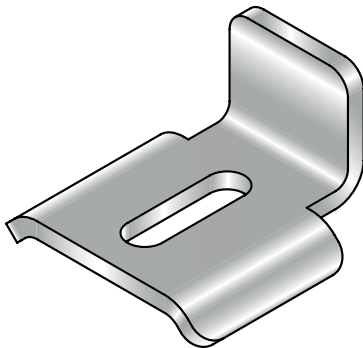

Notes for load data

Point of load application = pipe center line (X-axis).
 Load data per set (2 items) of the brackets installed with MP-PS x1-1 or MP-PS x2-2
 Load capacity given at room temperature.
 Temperature correction factors apply:

- Per VGB-R-510 for load reported acc to EN13480-3
- Per EN 1993-1-2 for loads reported acc to EN1993-1-1

Temperature distribution on pipe shoe components per EN13480-3
 Published loads are based on static loading conditions. Non-static forces must be separately considered during design

Recommended loads per EN13480-3

$\pm F_{x,rec}$ [kN]	$\pm F_{y,rec}$ [kN]	$+F_{z,rec}$ [kN]	$-F_{z,rec}$ [kN]
not decisive	2.21	not decisive	not decisive

Recommended loads per EN1993-1-1⁽²⁾

$\pm F_{x,rec}$ [kN]	$\pm F_{y,rec}$ [kN]	$+F_{z,rec}$ [kN]	$-F_{z,rec}$ [kN]
not decisive	4.90	not decisive	not decisive

⁽²⁾Notes

Shown EN1993-1-1 load values are recommended values with partial safety factors for action and resistance included. Design value in Y direction = 1.0 x recommended value. Shown load values apply for piece parts mounted with MT-TFB and X-BT, respectively.

MT-FPS-GL2 OC

Item no.	Material Description
2331081	Connector Pipe shoe MT-FPS-GL2 OC

General

- Media temperature limits: -20 °C to +300 °C
- Mass per single item: 0.182 kg
- Continuously hot-dip Zinc-Magnesium coated per EN 10346

Material properties:

Component/Material	min. Yield strength	min. Ultimate strength	Modulus of elasticity	Shear modulus
S280GD (EN 10346)	$f_y = 280 \frac{\text{N}}{\text{mm}^2}$	$f_u = 360 \frac{\text{N}}{\text{mm}^2}$	$E = 210000 \frac{\text{N}}{\text{mm}^2}$	$G = 80769 \frac{\text{N}}{\text{mm}^2}$

Values for Modulus of Elasticity and Shear Modulus are according to EN 1993-1-1 and used for all Eurocode calculations

DESIGN LOADING CAPACITY – 3D

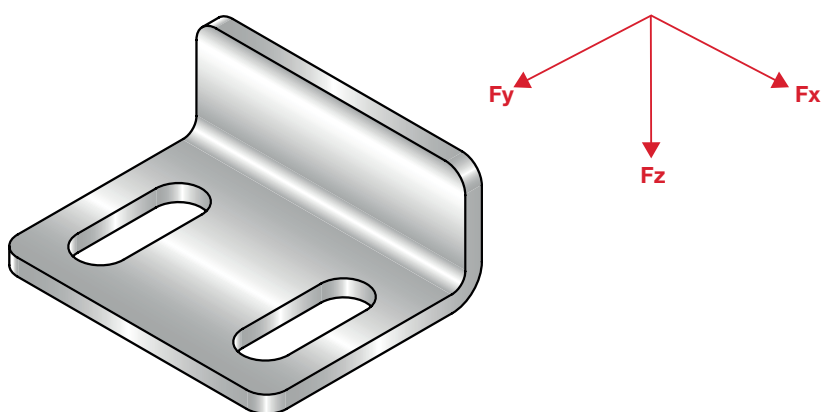

Notes for load data

Point of load application = pipe center line (X-axis). Load data per set (2 items) of the brackets installed with MP-PS x1-1, MP-PS x2-2, or MP-PS x4-2 according to IFU. Load capacity given at room temperature. Temperature correction factors apply:

- Per VGB-R-510 for load reported acc to EN13480-3
- Per EN 1993-1-2 for loads reported acc to EN1993-1-1

Temperature distribution on pipe shoe components per EN13480-3
Published loads are based on static loading conditions. Non-static forces must be separately considered during design

Recommended loads per EN13480-3

$\pm F_{x,rec}$ [kN]	$\pm F_{y,rec}$ [kN]	$+F_{z,rec}$ [kN]	$-F_{z,rec}$ [kN]
not decisive	3.14	not decisive	not decisive

Recommended loads per EN1993-1-1⁽²⁾

$\pm F_{x,rec}$ [kN]	$\pm F_{y,rec}$ [kN]	$+F_{z,rec}$ [kN]	$-F_{z,rec}$ [kN]
not decisive	6.95	not decisive	not decisive

⁽²⁾Notes

Shown EN1993-1-1 load values are recommended values with partial safety factors for action and resistance included. Design value in Y direction = 1.0 x recommended value. Shown load values apply for piece parts mounted with MT-TFB and X-BT, respectively.

MIA-BO90/120-M12

Item no.	Material Description
304840	Bow MIA-BO90-M12
304841	Bow MIA-BO120-M12

General

- Media temperature limits: -20 °C to +300 °C
- Mass per single item: 0.29 kg (MIA-BO90-M12); 0.33 kg (MIA-BO120-M12)
- Surface finish: HDG: 48 µm - DIN EN ISO 10684

Material properties:

Component/Material	min. Yield strength	min. Ultimate strength	Modulus of elasticity	Shear modulus
U-Bolt F Class 8.8 (ISO 898-1)	$f_y = 640 \frac{\text{N}}{\text{mm}^2}$	$f_u = 800 \frac{\text{N}}{\text{mm}^2}$	$E = 210000 \frac{\text{N}}{\text{mm}^2}$	$G = 80769 \frac{\text{N}}{\text{mm}^2}$
Nuts Grade 8 (ISO 898-2)	$f_y = 640 \frac{\text{N}}{\text{mm}^2}$	$f_u = 800 \frac{\text{N}}{\text{mm}^2}$	$E = 210000 \frac{\text{N}}{\text{mm}^2}$	$G = 80769 \frac{\text{N}}{\text{mm}^2}$

Values for Modulus of Elasticity and Shear Modulus are according to EN 1993-1-1 and used for all Eurocode calculations

DESIGN LOADING CAPACITY – 3D

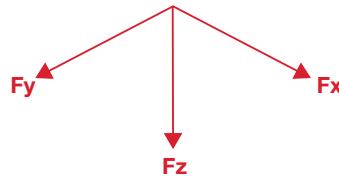
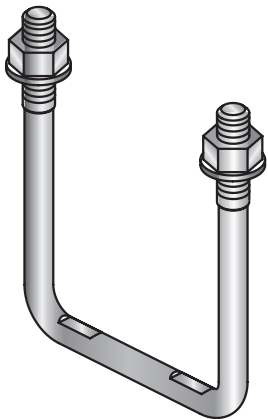

Notes for load data

Point of load application = pipe center line (X-axis). Load data per configuration (2 or 4 items) of the brackets installed with MP-PS x2-2, and MP-PS x4-2.

Load capacity given at room temperature. Temperature correction factors apply per EN 1993-1-2

Published loads are based on static loading conditions. Non-static forces must be separately considered during design. Installation in combination with MP-PS x2-2, and MP-PS x4-2 has to be done according to IFU of MP-PS

Recommended loads per EN1993-1-1⁽²⁾

Configurations	+/-F _{x,rec} [kN]	+/-F _{y,rec} [kN]	+F _{z,rec} [kN]	-F _{z,rec} [kN]
2 brackets	18.00	5.40	not decisive	11.11
4 brackets	36.00	10.80	not decisive	22.22

⁽²⁾Notes

Shown EN1993-1-1 load values are recommended values with partial safety factors for action and resistance included. Design value in X & Y directions = 1.0 x recommended value. Design value in Z direction = 1.35 x recommended value.

Interaction formula

$$\frac{F_{x,exp}}{F_{x,rec}} + \frac{F_{y,exp}}{F_{y,rec}} + \frac{F_{z,exp}}{F_{z,rec}} \leq 1.0$$

MI-DGC 90

Item no.	Material Description
233860	Beam clamp MI-DGC 90

General

- Media temperature limits: -20 °C to +300 °C
- Mass per single item: 1.02 kg (MI-DGC 90)
- Surface finish: HDG: Clamp 55 µm - DIN EN ISO 1461; U-bolt, Nut 45 µm - DIN EN ISO 1461

Material properties:

Component/Material	min. Yield strength	min. Ultimate strength	Modulus of elasticity	Shear modulus
U-Bolt, Nut F Class 8.8 (ISO 898-1); Grade 8 (ISO 898-2)	$f_y = 640 \frac{N}{mm^2}$	$f_u = 800 \frac{N}{mm^2}$	$E = 210000 \frac{N}{mm^2}$	$G = 80769 \frac{N}{mm^2}$
Clamp Steel EN-GJMB-350-10 - DIN EN 1562, Steel EN-GJMW-400-5 - DIN EN 1562, Steel EN-GJMB-450-6 - EN 1562	$f_y = 270 \frac{N}{mm^2}$	$f_u = 450 \frac{N}{mm^2}$	$E = 210000 \frac{N}{mm^2}$	$G = 80769 \frac{N}{mm^2}$

Values for Modulus of Elasticity and Shear Modulus are according to EN 1993-1-1 and used for all Eurocode calculations

DESIGN LOADING CAPACITY – 3D

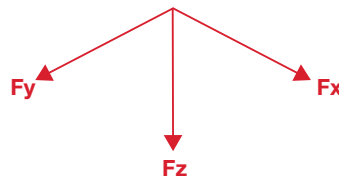
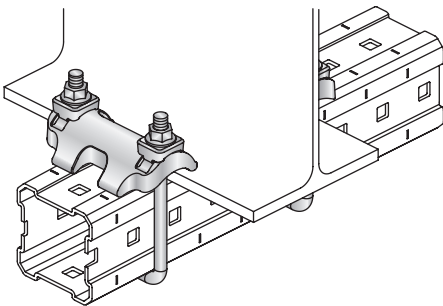

Notes for load data

Point of load application = pipe center line (X-axis).
Load data per set (2 items) of the brackets installed with MP-PS x1-1

Load capacity given at room temperature.
Temperature correction factors apply per EN 1993-1-2

Published loads are based on static loading conditions. Non-static forces must be separately considered during design.

Recommended loads per EN1993-1-1⁽²⁾

$\pm F_{x,rec}$ [kN]	$\pm F_{y,rec}$ [kN]	$+F_{z,rec}$ [kN]	$-F_{z,rec}$ [kN]	$M_{x,rec}$ [kNm]	$M_{y,rec}$ [kNm]	$M_{z,rec}$ [kNm]
6.09	8.93	not decisive	25.80	1.95	1.77	0.34

⁽²⁾Notes

Shown EN1993-1-1 load values are recommended values with partial safety factors for action and resistance included. Design value in X, Y, Mx, My & Mz directions = 1.0 x recommended value. Design value in Z direction = 1.35 x recommended value.

Interaction formula

$$\frac{F_{z,exp}}{F_{z,rec}} + \frac{M_{x,exp} + F_{y,exp} * \frac{(h+45)}{1000}}{M_{x,rec}} + \frac{M_{y,exp} + F_{x,exp} * \frac{(h+45)}{1000}}{M_{y,rec}} \leq 1.0$$

$$\sqrt{\left(\frac{F_{y,exp}}{F_{y,rec}}\right)^2 + \left(\frac{F_{x,exp} + \frac{M_{z,exp}}{M_{z,rec}}}{F_{x,rec}}\right)^2} \leq 1.0$$

MI-DGC 120

Item no.	Material Description
233861	Beam clamp MI-DGC 120

General

- Media temperature limits: -20 °C to +300 °C
- Mass per single item: 1.04 kg (MIC-DGC 120)
- Surface finish: HDG: Clamp 55 µm - DIN EN ISO 1461; U-bolt, Nut 45 µm - DIN EN ISO 1461

Material properties:

Component/Material	min. Yield strength	min. Ultimate strength	Modulus of elasticity	Shear modulus
U-Bolt, Nut F Class 8.8 (ISO 898-1); Grade 8 (ISO 898-2)	$f_y = 640 \frac{\text{N}}{\text{mm}^2}$	$f_u = 800 \frac{\text{N}}{\text{mm}^2}$	$E = 210000 \frac{\text{N}}{\text{mm}^2}$	$G = 80769 \frac{\text{N}}{\text{mm}^2}$
Clamp Steel EN-GJMB-350-10 - DIN EN 1562, Steel EN-GJMW-400-5 - DIN EN 1562, Steel EN-GJMB-450-6 - EN 1562	$f_y = 270 \frac{\text{N}}{\text{mm}^2}$	$f_u = 450 \frac{\text{N}}{\text{mm}^2}$	$E = 210000 \frac{\text{N}}{\text{mm}^2}$	$G = 80769 \frac{\text{N}}{\text{mm}^2}$

Values for Modulus of Elasticity and Shear Modulus are according to EN 1993-1-1 and used for all Eurocode calculations

DESIGN LOADING CAPACITY – 3D

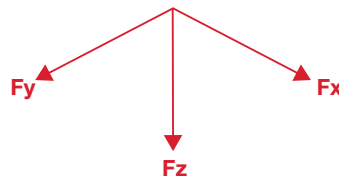
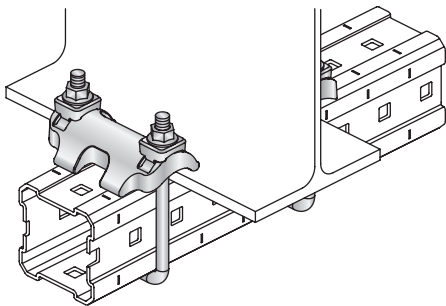

Notes for load data

Point of load application = pipe center line (X-axis).
Load data per set (2 items) of the brackets installed with MP-PS x1-1

Load capacity given at room temperature.
Temperature correction factors apply per EN 1993-1-2

Published loads are based on static loading conditions. Non-static forces must be separately considered during design.

Recommended loads per EN1993-1-1⁽²⁾

+/-F _{x,rec} [kN]	+/-F _{y,rec} [kN]	+F _{z,rec} [kN]	-F _{z,rec} [kN]	M _{x,rec} [kNm]	M _{y,rec} [kNm]	M _{z,rec} [kNm]
6.09	8.93	not decisive	25.80	1.95	1.77	0.34

⁽²⁾Notes

Shown EN1993-1-1 load values are recommended values with partial safety factors for action and resistance included. Design value in X, Y, M_x, M_y & M_z directions = 1.0 x recommended value. Design value in Z direction = 1.35 x recommended value.

Interaction formula

$$\frac{F_{z.exp}}{F_{z.rec}} + \frac{M_{x.exp} + F_{y.exp} * \frac{(h+60)}{1000}}{M_{x.rec}} + \frac{M_{y.exp} + F_{x.exp} * \frac{(h+60)}{1000}}{M_{y.rec}} \leq 1.0$$

$$\sqrt{\left(\frac{F_{y.exp}}{F_{y.rec}}\right)^2 + \left(\frac{F_{x.exp} + \frac{M_{z.exp}}{M_{z.rec}}}{F_{x.rec}}\right)^2} \leq 1.0$$

MIC-PS90/120

Item no.	Material Description
304838	Connector pipe shoe MIA-BO90-M12
304839	Connector pipe shoe MIA-BO120-M12

General

- Media temperature limits: -20 °C to +300 °C
- Mass per single item: 0.29 kg (MIC-PS90); 0.33 kg (MIC-PS120)
- Surface finish: HDG: U-bolt, nut 45 µm - DIN EN ISO 1461; plate: 55 µm - DIN EN ISO 1461

Material properties:

Component/Material	min. Yield strength	min. Ultimate strength	Modulus of elasticity	Shear modulus
U-Bolt, Nut F Class 8.8 (ISO 898-1); Grade 8 (ISO 898-2)	$f_y = 640 \frac{\text{N}}{\text{mm}^2}$	$f_u = 800 \frac{\text{N}}{\text{mm}^2}$	$E = 210000 \frac{\text{N}}{\text{mm}^2}$	$G = 80769 \frac{\text{N}}{\text{mm}^2}$
Plate DD11 MD - HN547 S235JR - DIN10025	$f_y = 235 \frac{\text{N}}{\text{mm}^2}$	$f_u = 350 \frac{\text{N}}{\text{mm}^2}$	$E = 210000 \frac{\text{N}}{\text{mm}^2}$	$G = 80769 \frac{\text{N}}{\text{mm}^2}$

Values for Modulus of Elasticity and Shear Modulus are according to EN 1993-1-1 and used for all Eurocode calculations

DESIGN LOADING CAPACITY – 3D

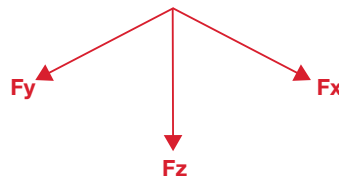
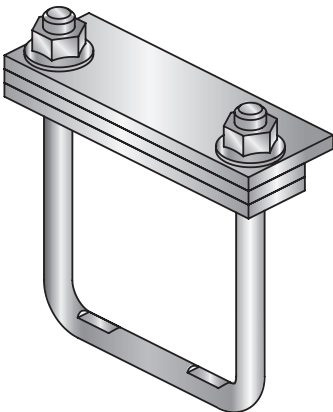

Notes for load data

Point of load application = pipe center line (X-axis). Load data per configuration (2 items or 4 items) of the brackets installed with MP-PS x1-1, MP-PS x2-2, or MP-PS x4-2 according to IFU.

Load capacity given at room temperature. Temperature correction factors apply per EN 1993-1-2. Published loads are based on static loading conditions. Non-static forces must be separately considered during design.

Recommended loads per EN1993-1-1⁽²⁾

Configurations	+/-F _{x,rec} [kN]	+/-F _{y,rec} [kN]	+F _{z,rec} [kN]	-F _{z,rec} [kN]
2 brackets	not decisive	6.30	not decisive	6.67
4 brackets	not decisive	12.60	not decisive	13.33

⁽²⁾Notes

Shown EN1993-1-1 load values are recommended values with partial safety factors for action and resistance included. Design value in Y direction = 1.0 x recommended value. Design value in Z direction = 1.35 x recommended value.

Interaction formula

$$\frac{F_{y,exp}}{F_{y,rec}} + \frac{F_{z,exp}}{F_{z,rec}} \leq 1.0$$

MP-PS IFG

MP-PS IFG:

Item no.	Material Description	Mass (kg)
2331072	Beam connector MP-PS IFG 80/160 OC	1.97
2331073	Beam connector MP-PS IFG 160/230 OC	2.23
2331074	Beam connector MP-PS IFG 230/300 OC	2.49

General

- Media temperature limits: -20 °C to +300 °C

Material properties:

Component/Material	min. Yield strength	min. Ultimate strength	Modulus of elasticity	Shear modulus
Beam Clamp Cast Iron (DIN EN 1562)	$f_y = 270 \frac{N}{mm^2}$	$f_u = 450 \frac{N}{mm^2}$	$E = 210000 \frac{N}{mm^2}$	$G = 80769 \frac{N}{mm^2}$
Baseplate S280GD (EN 10346)	$f_y = 280 \frac{N}{mm^2}$	$f_u = 360 \frac{N}{mm^2}$	$E = 210000 \frac{N}{mm^2}$	$G = 80769 \frac{N}{mm^2}$
Rectangular washer S235JR Yield280 (HN 707)	$f_y = 280 \frac{N}{mm^2}$	$f_u = 360 \frac{N}{mm^2}$	$E = 210000 \frac{N}{mm^2}$	$G = 80769 \frac{N}{mm^2}$
Bolts; Nuts F Class 8.8 (ISO 898-1); Grade 8 (ISO 898-2)	$f_y = 640 \frac{N}{mm^2}$	$f_u = 800 \frac{N}{mm^2}$	$E = 210000 \frac{N}{mm^2}$	$G = 80769 \frac{N}{mm^2}$
Cylindrical washers Stainless Steel X5CrNi18-10 (EN 10088-3)	$f_y = 190 \frac{N}{mm^2}$	$f_u = 500 \frac{N}{mm^2}$	$E = 210000 \frac{N}{mm^2}$	$G = 80769 \frac{N}{mm^2}$
Retaining washers C60E (EN10132-3)	$f_y = 450 \frac{N}{mm^2}$	$f_u = 750 \frac{N}{mm^2}$	$E = 210000 \frac{N}{mm^2}$	$G = 80769 \frac{N}{mm^2}$

Values for Modulus of Elasticity and Shear Modulus are according to EN 1993-1-1 and used for all Eurocode calculations

Corrosion protection:

Component	Coating system	Zinc thickness, min. local (μm)
Beam Clamp (Clamping Claw+Saddle)	HDG per ISO 1461	55
Retaining Washer	Non-electrolytically applied zinc flake coated per ISO 10683	5
Bolts; Nuts	HDG per ISO 10684	40
Baseplate	Continuously hot-dip Zinc-Magnesium coated per EN 10346	17
Rectangular washer	HDG per ISO 1461	55

DESIGN LOADING CAPACITY – 3D

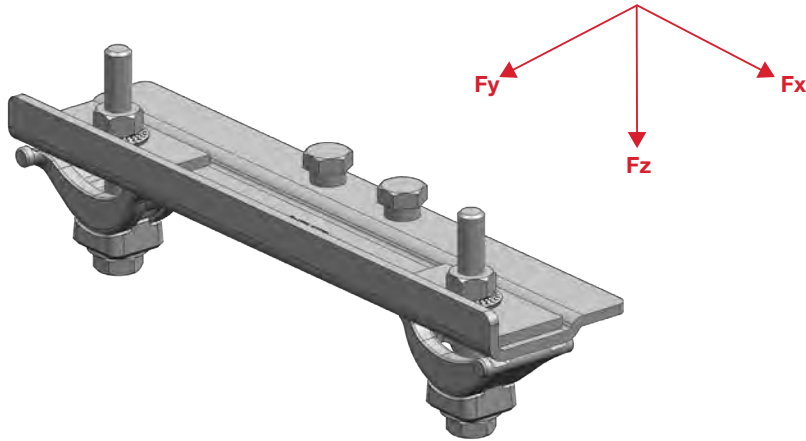

Notes for load data

Point of load application = pipe center line (X-Axis)
 Load data of the brackets installed with MP-PS x1-1, MP-PS x2-2, and MP-PS x4-2
 Load capacity given at room temperature
 Temperature correction factors apply:

- Per VGB-R-510 for load reported acc to EN13480-3
- Per EN 1993-1-2 for loads reported acc to EN1993-1-1

Temperature distribution on pipe shoe components per EN13480-3
 Published loads are based on static loading. Non-static forces must be separately considered during design
 Installation in combination with MP-PS x1-1, MP-PS x2-2, and MP-PS x4-2 has to be done according to IFU of MP-PS and IFG

Interaction formula

Fix Point:

$$\frac{F_{x.exp}}{F_{x.rec}} + \frac{F_{y.exp}}{F_{y.rec}} + \frac{F_{z.exp}}{F_{z.rec}} \leq 1.0$$

(2)Notes

Shown EN1993-1-1 load values are recommended values with partial safety factors for action and resistance included. Design value in X & Y directions = 1.0 x recommended value. Design value in Z direction = 1.35 x recommended value.

Recommended loads per EN13480-3 for IFG Fixpoint

		+/-F _{x,rec} [kN]	+/-F _{y,rec} [kN]		-F _{z,rec} [kN]	+F _{z,rec} [kN]
			Failure mode			
			slip of jaws	deformation of baseplate		
1x1 2x2	2 brackets	6.28	2.75	450.00/h*	10.68	not decisive
4x2	2 brackets			1149.75/h*		
		4 brackets	12.56	-	1722.19/h*	

*h – Height of pipe neutral axis in mm from pipe shoe base

Recommended loads per EN1993-1-1⁽²⁾ for IFG Fixpoint

		+/-F _{x,rec} [kN]	+/-F _{y,rec} [kN]		-F _{z,rec} [kN]	+F _{z,rec} [kN]
			Failure mode			
			slip of jaws	deformation of baseplate		
1x1 2x2	2 brackets	10.05	3.74	929.09/h*	15.20	not decisive
4x2	2 brackets			2373.83/h*		
		4 brackets	20.10	-	3555.72/h*	

*h – Height of pipe neutral axis in mm from pipe shoe base

MP-PS ISG

MP-PS ISG:

Item no.	Material Description	Mass (kg)
2343972	Beam connector MP-PS ISG 80/160 OC	1.92
2343973	Beam connector MP-PS ISG 160/230 OC	2.18
2343974	Beam connector MP-PS ISG 230/300 OC	2.44

General

- Media temperature limits: -20 °C to +300 °C

Material properties:

Component/Material	min. Yield strength	min. Ultimate strength	Modulus of elasticity	Shear modulus
Beam Clamp Cast Iron (DIN EN 1562)	$f_y = 270 \frac{N}{mm^2}$	$f_u = 450 \frac{N}{mm^2}$	$E = 210000 \frac{N}{mm^2}$	$G = 80769 \frac{N}{mm^2}$
Baseplate S280GD (EN 10346)	$f_y = 280 \frac{N}{mm^2}$	$f_u = 360 \frac{N}{mm^2}$	$E = 210000 \frac{N}{mm^2}$	$G = 80769 \frac{N}{mm^2}$
Rectangular washer S235JR Yield280 (HN 707)	$f_y = 280 \frac{N}{mm^2}$	$f_u = 360 \frac{N}{mm^2}$	$E = 210000 \frac{N}{mm^2}$	$G = 80769 \frac{N}{mm^2}$
Bolts; Nuts F Class 8.8 (ISO 898-1); Grade 8 (ISO 898-2)	$f_y = 640 \frac{N}{mm^2}$	$f_u = 800 \frac{N}{mm^2}$	$E = 210000 \frac{N}{mm^2}$	$G = 80769 \frac{N}{mm^2}$
Retaining washers C60E (EN10132-3)	$f_y = 450 \frac{N}{mm^2}$	$f_u = 750 \frac{N}{mm^2}$	$E = 210000 \frac{N}{mm^2}$	$G = 80769 \frac{N}{mm^2}$

Values for Modulus of Elasticity and Shear Modulus are according to EN 1993-1-1 and used for all Eurocode calculations

Corrosion protection:

Component	Coating system	Zinc thickness, min. local (µm)
Beam Clamp (Clamping Claw+Saddle)	HDG per ISO 1461	55
Retaining Washer	Non-electrolytically applied zinc flake coated per ISO 10683	5
Bolts; Nuts	HDG per ISO 10684	40
Baseplate	Continuously hot-dip Zinc-Magnesium coated per EN 10346	17
Rectangular washer	HDG per ISO 1461	55

DESIGN LOADING CAPACITY – 3D

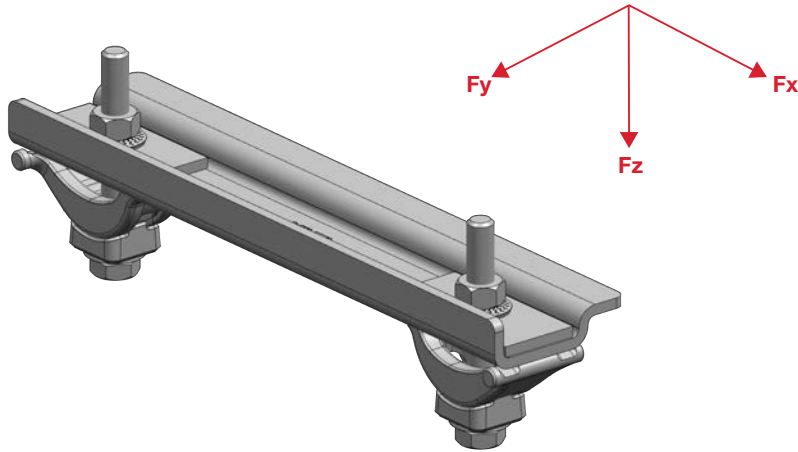

Notes for load data

Point of load application = pipe center line (X-Axis)
 Load data of the brackets installed with MP-PS x1-1, MP-PS x2-2, and MP-PS x4-2
 Load capacity given at room temperature
 Temperature correction factors apply:

- Per VGB-R-510 for load reported acc to EN13480-3
- Per EN 1993-1-2 for loads reported acc to EN1993-1-1

Temperature distribution on pipe shoe components per EN13480-3
 Published loads are based on static loading. Non-static forces must be separately considered during design
 Installation in combination with MP-PS x1-1, MP-PS x2-2, and MP-PS x4-2 has to be done according to IFU of MP-PS and ISG

Interaction formula

Line Guide:

$$\frac{F_{y.exp}}{F_{y.rec}} + \frac{F_{z.exp}}{F_{z.rec}} \leq 1.0$$

Plain Guide:

$$\frac{F_{y.exp}}{F_{y.rec}} \leq 1.0$$

(2)Notes

Shown EN1993-1-1 load values are recommended values with partial safety factors for action and resistance included. Design value in X & Y directions = 1.0 x recommended value. Design value in Z direction = 1.35 x recommended value.

Recommended loads per EN13480-3 for ISG Line and Plain Guide

		+/-F _{x,rec} [kN]	+/-F _{y,rec} [kN]		-F _{z,rec} [kN]	+F _{z,rec} [kN]
			Failure mode			
			slip of jaws	deformation of baseplate		
1x1 2x2	2 brackets	not decisive	2.75	450.00/h*	10.68	not decisive
4x2	2 brackets			1149.75/h*		
	4 brackets		-	1722.19/h*	21.36	

*h – Height of pipe neutral axis in mm from pipe shoe base

Recommended loads per EN1993-1-1⁽²⁾

		+/-F _{x,rec} [kN]	+/-F _{y,rec} [kN]		-F _{z,rec} [kN]	+F _{z,rec} [kN]
			Failure mode			
			slip of jaws	deformation of baseplate		
1x1 2x2	2 brackets	not decisive	3.74	929.09/h*	15.20	not decisive
4x2	2 brackets			2373.83/h*		
	4 brackets		-	3555.72/h*	30.40	

*h – Height of pipe neutral axis in mm from pipe shoe base

MT-FPS Adapter Plate

Adapter plate to mount third-party pipe shoe portfolio on MT girders.

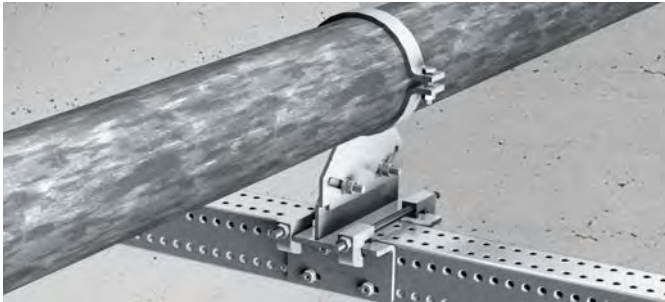

Applications

- Fastening pipes with H-beam ready clamping systems on MT support structure
- Suitable for use in moderately corrosive environments
- Adapter component for pipe supports based on traditional clamping systems
- Solution for extended thermal expansion requirements

Advantages

- The adapter plates replace the steel beam flange, thus allowing use of conventional clamping systems for pipe supports
- Part of the Hilti MT system – an economical, all-in-one solution for virtually all modular MEP support structures
- Significantly extends thermal expansion possibilities for MP-PS pipe shoes on MT girders
- Easy to install – one-step fastening to MT girders using MT-TFB thread-forming bolts
- Load data and documentation available – design according to EN13480-3 and EN-1993 guidelines for pipe support components

Technical data

Material composition	S355JR	
For use with	MT-Girders	
Surface finish	Hot-dip galvanized, 70µm - DIN EN ISO 1461	
Item no.	Material Description	Mass (kg)
2368806	Adapter plate MT-FPS-AP OC	1.25

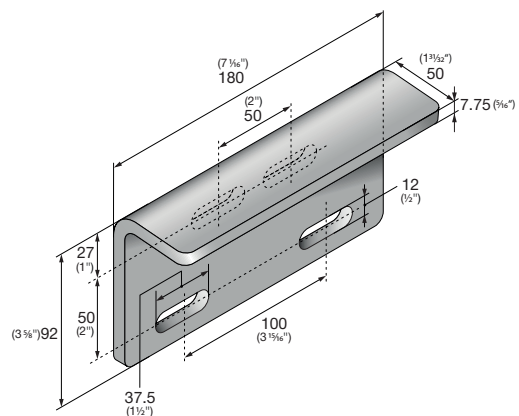

MT-FPS-AP TECHNICAL DATA

Recommended Loading per EN-1993

$\pm F_x$, rec [kN]	$\pm F_y$, rec [kN]	$-F_z$, rec [kN]
37.9	9.7	3700/h* 32.0

*h – Height of pipe neutral axis in mm from pipe shoe base

Recommended Loading per EN13480-3

$\pm F_x$, rec [kN]	$\pm F_y$, rec [kN]	$-F_z$, rec [kN]
27.1	14.7	4200/h* 30.5

*h – Height of pipe neutral axis in mm from pipe shoe base

Note:

Load data per set (2 items) of the brackets installed according to IFU. Load capacity given at room temperature. Published loads are based on static loading conditions. Non-static forces must be separately considered during design.

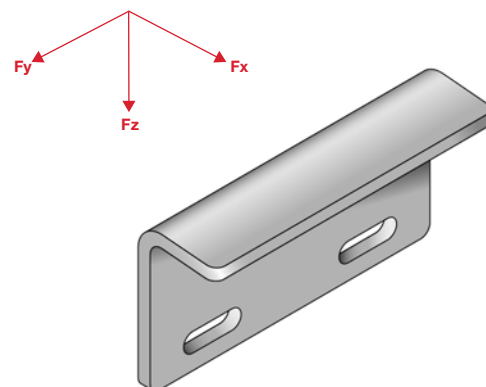

MT-SP OC Slider plate

Universal low-friction interface for use between pipe and the MT girders with improved temperature and UV-resistance



Applications

- Facilitating pipe shoe movement due to thermal expansion or contraction
- Prevents contact corrosion between pipe and support system
- Insulating against heat transfer from media to the surrounding girders
- Suitable for application temperature of up to 150°C (302°F) and can be used in Indoor or Outdoor
- Can be used with all boxed profiles from MT-70 up to MT-100 as well as with MT-U-GL1

Advantages

- Part of the Hilti MT system – an economical, all-in-one solution for virtually all modular MEP support structures
- Improved temperature and UV resistance allows to be used in versatile heat conditions with media temperature of up to 150°C (302°F) and ensures extended lifetime Indoor and Outdoor
- Easy to fix to MT girders with a snap-fit mechanism in a horizontal, vertical, and overhead orientation
- Robust solution for line and plain guides in combination with U-bolts, pipe shoes

Technical data

Material composition	PA66-GF30 UV-stabilised
For use with	MT-Girders, MT-U-GL1
Surface finish	n/a
Temperature resistance	-40°C (-40°F) up to 150°C (302°F)

Item no.	Material Description	Mass (kg)
2368807	Slider plate MT-SP	0.25

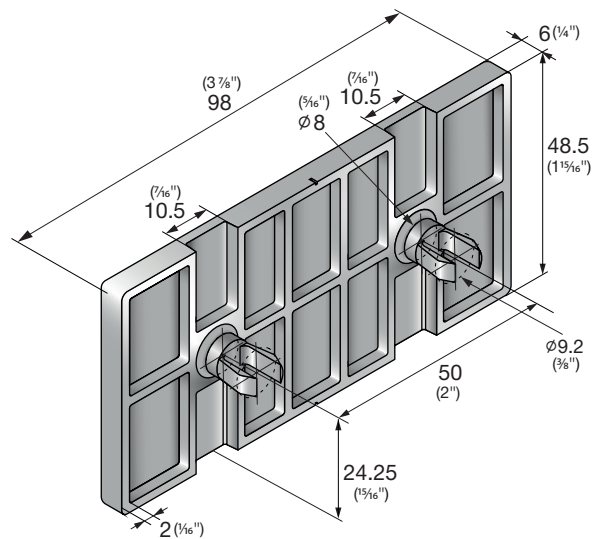

MT-SP TECHNICAL DATA

Recommended Loads

Standard	+/- F _{y,rec} [kN] pure shear load
EN-1993	2.83
EN13480-3	2.43

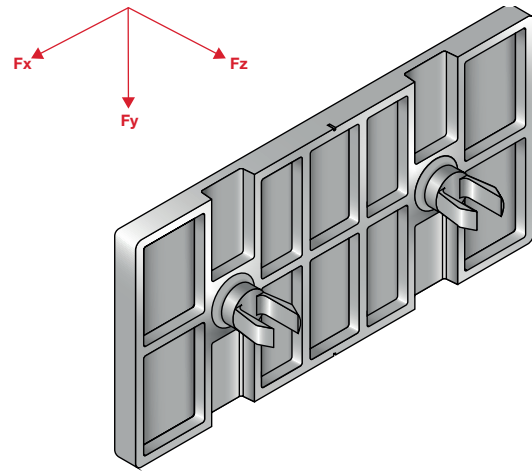

Notes: Load data per item installed according to IFU.

Load capacity given at room temperature. Published loads are based on static loading conditions.

Design load value per EN-1993 = 1.5 x recommended value.

Non-static forces must be separately considered during design.

Coefficient of Friction

R	Slider plate material	Mating surface	Friction coefficient	
			Static	Kinetic
1	PA66, GF30 ¹⁾	Hot Dip Galvanized coated ²⁾	0.13	0.10
2		Zinc-Magnesium coated ³⁾	0.15	0.10
3		Zinc Electrogalvanized coated ⁴⁾	0.18	0.10
4		PA66, GF30 ¹⁾	0.24	0.15
5		Normal black steel pipes ⁵⁾	0.24	0.16

1) Test performed on 10cm x 15cm PA66, GF30 block sample

2) Test performed on MQ-41-F channel (Hilti material no. #304100)

3) Test performed on MT-50 channel (Hilti material no. #2268510)

4) Test performed on MQ-41-L channel (Hilti material no. #2141964)

5) Test performed on DIN EN 10220:2002 uncoated steel pipe DN70 (2 1/2")



Hilti Aktiengesellschaft
9494 Schaan, Liechtenstein
P +423-234 2965

www.facebook.com/hiltigroup
www.hilti.group