

NL

PRESTATIEVERKLARING

in overeenstemming met Bijlage III van de Verordening (EU) nr. 305/2011 (Richtlijn bouwproducten)

 Hilti zelftappende schroeven S-MS Z, S-MS C
 Nr. Hilti-SF-DoP-003

- 1. Unieke identificatiecode van het producttype:** Hilti zelftappende schroeven S-MD Z, S-MD C
- 2. Type-, partij- of serienummer, dan wel enig ander identificatiemiddel voor het bouwproduct, zoals voorgeschreven in artikel 11, lid 4:** type- en partijnummer vermeld op de verpakking
- 3. Beoogd(e) gebruik(en) van het bouwproduct, in overeenstemming met de toepasselijke geharmoniseerde technische specificatie, zoals door de fabrikant bepaald:**

Generiek type en gebruik	Zelftappende bevestigingsschroeven voor metalen balken en bekleding
Gedekte productgrootte	Schroefdiameter 4,8 mm
Basis en bevestigd materiaal	Staal volgens EN 10346 Aluminiumlegering conform EN 485 / EN 573
Bevestigingsmateriaal	Verzinkt of gecoat, gehard koolstofstaal conform EN 10084
Belasting	Statisch en quasi-statisch (windbelasting)

- 4. De naam, de gedeponeerde handelsnaam of het gedeponeerde handelsmerk, en het contactadres van de fabrikant zoals vereist volgens artikel 11, lid 5:** Hilti Aktiengesellschaft, Business Unit Direct FASTening, 9494 Schaan, Fürstentum Liechtenstein
- 5. Indien van toepassing, naam en contactadres van de gemachtigde wiens mandaat de in artikel 12, lid 2, vermelde taken bestrijkt:** n.v.t.
- 6. Systeem of systemen voor de beoordeling en verificatie van de prestatiebestendigheid van het bouwproduct, zoals vermeld in bijlage V:** systeem 2+
- 7. Indien de prestatieverklaring betrekking heeft op een bouwproduct dat onder een geharmoniseerde norm valt:** n.v.t.

8. Indien de prestatieverklaring betrekking heeft op een bouwproduct waarvoor een Europese Technische Beoordeling is afgegeven:

Aan de basis van EAD 330046-01-0602 afgegeven ETA-10/0182. De aangemelde instantie MPA-Karlsruhe 0769 voerde taken van derden uit onder systeem 2+ en gaf het certificaat van overeenstemming van de productiecontrole af.

9. Aangegeven prestatie(s):

Essentiële kenmerken	Prestaties	Geharmoniseerde technische specificatie
Kenmerkende trekweerstand $N_{R,k}$	Bijlage 1 - 6 ETA-10/0182 (Bijlage 4 – 9)	ETA-10/0182 EAD 330046-01-0602
Karakteristieke schuifweerstand $V_{R,k}$		
Verbindingstypes		
Toepassingslimieten		
Reactie op brand	A1	

- 10. De prestaties van het onder punt 1 en 2 omschreven product zijn conform de in punt 9 aangegeven prestaties. Deze prestatieverklaring wordt onder de exclusieve verantwoordelijkheid van de in punt 4 vermelde fabrikant verstrekt.**

Ondertekend voor en namens de fabrikant door:

Lars Taenzer
Head of Business Unit Direct Fastening

Pierre Hohmeier
Head of Quality Screw Fastening

Hilti Aktiengesellschaft, Schaan, 03.05.2019

Annex 1:
ETA-10/0182, Annex 4

	<p>Material:</p> <p>Fastener: carbon steel, case hardened and galvanized or coated</p> <p>Washer: none</p> <p>Component I: S280GD, S320GD, S350GD - EN 10346</p> <p>Component II: S280GD, S320GD, S350GD - EN 10346</p>
	<p>Drilling capacity: $\Sigma t_i \leq 2,50$ mm</p>
<p>Timber substructures: no performance determined</p>	

t [mm]	t _i [mm]								
	0,50	0,55	0,63	0,75	0,88	1,00	1,13	1,25	
V _{0,x} [kN]	0,50	1,29	1,37	1,51	1,71	1,71	1,71	1,71	1,71
	0,55	1,29	1,54	1,65	1,82	1,82	1,82	1,82	2,05
	0,63	1,29	1,54	1,80	2,00	2,00	2,00	2,00	2,59
	0,75	1,29	1,54	1,80	2,27	2,27	2,27	2,84	3,40
	0,88	1,29	1,54	1,80	2,27	2,96	2,96	2,96	3,40
	1,00	1,29	1,54	1,80	2,27	2,96	3,64	3,64	3,64
	1,13	1,29	1,54	1,80	2,27	2,96	3,64	3,87	3,87
	1,25	1,29	1,54	1,80	2,27	2,96	3,64	3,87	4,10
	1,50	1,29	1,54	1,80	2,27	2,96	3,64	—	—
	1,75	1,29	1,54	1,80	2,27	—	—	—	—
	2,00	1,29	—	—	—	—	—	—	—
N _{0,x} [kN]	0,50	0,76	0,87	1,04	1,29	1,56	1,82	1,93	1,93
	0,55	0,76	0,87	1,04	1,29	1,56	1,82	2,09	2,25
	0,63	0,76	0,87	1,04	1,29	1,56	1,82	2,09	2,34
	0,75	0,76	0,87	1,04	1,29	1,56	1,82	2,09	2,34
	0,88	0,76	0,87	1,04	1,29	1,56	1,82	2,09	2,34
	1,00	0,76	0,87	1,04	1,29	1,56	1,82	2,09	2,34
	1,13	0,76	0,87	1,04	1,29	1,56	1,82	2,09	2,34
	1,25	0,76	0,87	1,04	1,29	1,56	1,82	2,09	2,34
	1,50	0,76	0,87	1,04	1,29	1,56	1,82	—	—
	1,75	0,76	0,87	1,04	1,29	—	—	—	—
	2,00	0,76	—	—	—	—	—	—	—
M _{0,perm} [Nm]									

No additional regulations.

Self piercing screw	Annex 4
Hilti S-MS 01 Z 4,8 x L Hilti S-MS 01 C 4,8 x L with hexagon head	

Annex 2:
ETA-10/0182, Annex 5

	<p>Material:</p> <p>Fastener: carbon steel, case hardened and galvanized or coated</p> <p>Washer: carbon steel, galvanized or coated stainless Steel (1.4301) - EN 10088</p> <p>Component I: S280GD, S320GD, S350GD - EN 10346</p> <p>Component II: S280GD, S320GD, S350GD - EN 10346</p>																																																																																																																																																																																																																																																																																																																																													
	<p>Drilling capacity: $\Sigma t_i \leq 2,50$ mm</p>																																																																																																																																																																																																																																																																																																																																													
<p>Timber substructures: no performance determined</p>																																																																																																																																																																																																																																																																																																																																														
<table border="1"> <thead> <tr> <th rowspan="2"></th> <th rowspan="2">t_i [mm]</th> <th colspan="12">t_i [mm]</th> </tr> <tr> <th>0,40</th><th>0,50</th><th>0,55</th><th>0,63</th><th>0,75</th><th>0,88</th><th>1,00</th><th>1,25</th> <th>0,40</th><th>0,50</th><th>0,55</th><th>0,63</th><th>0,75</th><th>0,88</th><th>1,00</th><th>1,25</th> </tr> </thead> <tbody> <tr> <td rowspan="8">V_{Rk} [kN]</td> <td>0,40</td><td>0,81</td><td>0,87</td><td>0,90</td><td>0,95</td><td>1,03</td><td>1,03</td><td>1,03</td><td>1,03</td><td>1,03</td><td>1,03</td><td>1,03</td><td>1,03</td><td>1,03</td><td>1,03</td><td>1,03</td><td>1,03</td> </tr> <tr> <td>0,50</td><td>0,81</td><td>1,01</td><td>1,01</td><td>1,02</td><td>1,03</td><td>1,03</td><td>1,03</td><td>1,03</td><td>1,03</td><td>1,03</td><td>1,03</td><td>1,03</td><td>1,03</td><td>1,03</td><td>1,03</td><td>1,03</td> </tr> <tr> <td>0,55</td><td>0,81</td><td>1,01</td><td>1,26</td><td>1,26</td><td>1,26</td><td>1,26</td><td>1,26</td><td>1,26</td><td>1,26</td><td>1,26</td><td>1,26</td><td>1,26</td><td>1,26</td><td>1,26</td><td>1,26</td><td>1,26</td> </tr> <tr> <td>0,63</td><td>0,81</td><td>1,01</td><td>1,26</td><td>1,66</td><td>1,66</td><td>1,66</td><td>1,66</td><td>1,66</td><td>1,66</td><td>1,66</td><td>1,66</td><td>1,66</td><td>1,66</td><td>1,66</td><td>1,66</td><td>1,66</td> </tr> <tr> <td>0,75</td><td>0,81</td><td>1,01</td><td>1,26</td><td>1,66</td><td>2,26</td><td>2,26</td><td>2,26</td><td>2,26</td><td>2,26</td><td>2,26</td><td>2,26</td><td>2,26</td><td>2,26</td><td>2,26</td><td>2,26</td><td>2,26</td> </tr> <tr> <td>0,88</td><td>0,81</td><td>1,01</td><td>1,26</td><td>1,66</td><td>2,26</td><td>2,77</td><td>2,77</td><td>2,77</td><td>2,77</td><td>2,77</td><td>2,77</td><td>2,77</td><td>2,77</td><td>2,77</td><td>2,77</td><td>2,77</td> </tr> <tr> <td>1,00</td><td>0,81</td><td>1,01</td><td>1,26</td><td>1,66</td><td>2,26</td><td>2,77</td><td>3,24</td><td>3,24</td><td>3,24</td><td>3,24</td><td>3,24</td><td>3,24</td><td>3,24</td><td>3,24</td><td>3,24</td><td>3,24</td> </tr> <tr> <td>1,25</td><td>0,81</td><td>1,01</td><td>1,26</td><td>1,66</td><td>2,26</td><td>2,77</td><td>3,24</td><td>4,24</td><td>4,24</td><td>4,24</td><td>4,24</td><td>4,24</td><td>4,24</td><td>4,24</td><td>4,24</td><td>4,24</td> </tr> <tr> <td rowspan="8">N_{Rk} [kN]</td> <td>0,40</td><td>0,46</td><td>0,76</td><td>0,88</td><td>1,03</td><td>1,27</td><td>1,43</td><td>1,43</td><td>1,43</td><td>1,43</td><td>1,43</td><td>1,43</td><td>1,43</td><td>1,43</td><td>1,43</td><td>1,43</td><td>1,43</td> </tr> <tr> <td>0,50</td><td>0,46</td><td>0,76</td><td>0,88</td><td>1,03</td><td>1,27</td><td>1,60</td><td>1,80</td><td>1,80</td><td>1,80</td><td>1,80</td><td>1,80</td><td>1,80</td><td>1,80</td><td>1,80</td><td>1,80</td><td>1,80</td> </tr> <tr> <td>0,55</td><td>0,46</td><td>0,76</td><td>0,88</td><td>1,03</td><td>1,27</td><td>1,60</td><td>1,90</td><td>1,90</td><td>1,90</td><td>1,90</td><td>1,90</td><td>1,90</td><td>1,90</td><td>1,90</td><td>1,90</td><td>1,90</td> </tr> <tr> <td>0,63</td><td>0,46</td><td>0,76</td><td>0,88</td><td>1,03</td><td>1,27</td><td>1,60</td><td>1,90</td><td>2,34</td><td>2,34</td><td>2,34</td><td>2,34</td><td>2,34</td><td>2,34</td><td>2,34</td><td>2,34</td><td>2,34</td> </tr> <tr> <td>0,75</td><td>0,46</td><td>0,76</td><td>0,88</td><td>1,03</td><td>1,27</td><td>1,60</td><td>1,90</td><td>2,49</td><td>2,49</td><td>2,49</td><td>2,49</td><td>2,49</td><td>2,49</td><td>2,49</td><td>2,49</td><td>2,49</td> </tr> <tr> <td>0,88</td><td>0,46</td><td>0,76</td><td>0,88</td><td>1,03</td><td>1,27</td><td>1,60</td><td>1,90</td><td>2,49</td><td>2,49</td><td>2,49</td><td>2,49</td><td>2,49</td><td>2,49</td><td>2,49</td><td>2,49</td><td>2,49</td> </tr> <tr> <td>1,00</td><td>0,46</td><td>0,76</td><td>0,88</td><td>1,03</td><td>1,27</td><td>1,60</td><td>1,90</td><td>2,49</td><td>2,49</td><td>2,49</td><td>2,49</td><td>2,49</td><td>2,49</td><td>2,49</td><td>2,49</td><td>2,49</td> </tr> <tr> <td>1,25</td><td>0,46</td><td>0,76</td><td>0,88</td><td>1,03</td><td>1,27</td><td>1,60</td><td>1,90</td><td>2,49</td><td>2,49</td><td>2,49</td><td>2,49</td><td>2,49</td><td>2,49</td><td>2,49</td><td>2,49</td><td>2,49</td> </tr> <tr> <td>M_{Rk} [Nm]</td> <td colspan="17"></td> </tr> </tbody> </table>														t_i [mm]	t_i [mm]												0,40	0,50	0,55	0,63	0,75	0,88	1,00	1,25	0,40	0,50	0,55	0,63	0,75	0,88	1,00	1,25	V_{Rk} [kN]	0,40	0,81	0,87	0,90	0,95	1,03	1,03	1,03	1,03	1,03	1,03	1,03	1,03	1,03	1,03	1,03	1,03	0,50	0,81	1,01	1,01	1,02	1,03	1,03	1,03	1,03	1,03	1,03	1,03	1,03	1,03	1,03	1,03	1,03	0,55	0,81	1,01	1,26	1,26	1,26	1,26	1,26	1,26	1,26	1,26	1,26	1,26	1,26	1,26	1,26	1,26	0,63	0,81	1,01	1,26	1,66	1,66	1,66	1,66	1,66	1,66	1,66	1,66	1,66	1,66	1,66	1,66	1,66	0,75	0,81	1,01	1,26	1,66	2,26	2,26	2,26	2,26	2,26	2,26	2,26	2,26	2,26	2,26	2,26	2,26	0,88	0,81	1,01	1,26	1,66	2,26	2,77	2,77	2,77	2,77	2,77	2,77	2,77	2,77	2,77	2,77	2,77	1,00	0,81	1,01	1,26	1,66	2,26	2,77	3,24	3,24	3,24	3,24	3,24	3,24	3,24	3,24	3,24	3,24	1,25	0,81	1,01	1,26	1,66	2,26	2,77	3,24	4,24	4,24	4,24	4,24	4,24	4,24	4,24	4,24	4,24	N_{Rk} [kN]	0,40	0,46	0,76	0,88	1,03	1,27	1,43	1,43	1,43	1,43	1,43	1,43	1,43	1,43	1,43	1,43	1,43	0,50	0,46	0,76	0,88	1,03	1,27	1,60	1,80	1,80	1,80	1,80	1,80	1,80	1,80	1,80	1,80	1,80	0,55	0,46	0,76	0,88	1,03	1,27	1,60	1,90	1,90	1,90	1,90	1,90	1,90	1,90	1,90	1,90	1,90	0,63	0,46	0,76	0,88	1,03	1,27	1,60	1,90	2,34	2,34	2,34	2,34	2,34	2,34	2,34	2,34	2,34	0,75	0,46	0,76	0,88	1,03	1,27	1,60	1,90	2,49	2,49	2,49	2,49	2,49	2,49	2,49	2,49	2,49	0,88	0,46	0,76	0,88	1,03	1,27	1,60	1,90	2,49	2,49	2,49	2,49	2,49	2,49	2,49	2,49	2,49	1,00	0,46	0,76	0,88	1,03	1,27	1,60	1,90	2,49	2,49	2,49	2,49	2,49	2,49	2,49	2,49	2,49	1,25	0,46	0,76	0,88	1,03	1,27	1,60	1,90	2,49	2,49	2,49	2,49	2,49	2,49	2,49	2,49	2,49	M_{Rk} [Nm]																	
	t_i [mm]	t_i [mm]																																																																																																																																																																																																																																																																																																																																												
		0,40	0,50	0,55	0,63	0,75	0,88	1,00	1,25	0,40	0,50	0,55	0,63	0,75	0,88	1,00	1,25																																																																																																																																																																																																																																																																																																																													
V_{Rk} [kN]	0,40	0,81	0,87	0,90	0,95	1,03	1,03	1,03	1,03	1,03	1,03	1,03	1,03	1,03	1,03	1,03	1,03																																																																																																																																																																																																																																																																																																																													
	0,50	0,81	1,01	1,01	1,02	1,03	1,03	1,03	1,03	1,03	1,03	1,03	1,03	1,03	1,03	1,03	1,03																																																																																																																																																																																																																																																																																																																													
	0,55	0,81	1,01	1,26	1,26	1,26	1,26	1,26	1,26	1,26	1,26	1,26	1,26	1,26	1,26	1,26	1,26																																																																																																																																																																																																																																																																																																																													
	0,63	0,81	1,01	1,26	1,66	1,66	1,66	1,66	1,66	1,66	1,66	1,66	1,66	1,66	1,66	1,66	1,66																																																																																																																																																																																																																																																																																																																													
	0,75	0,81	1,01	1,26	1,66	2,26	2,26	2,26	2,26	2,26	2,26	2,26	2,26	2,26	2,26	2,26	2,26																																																																																																																																																																																																																																																																																																																													
	0,88	0,81	1,01	1,26	1,66	2,26	2,77	2,77	2,77	2,77	2,77	2,77	2,77	2,77	2,77	2,77	2,77																																																																																																																																																																																																																																																																																																																													
	1,00	0,81	1,01	1,26	1,66	2,26	2,77	3,24	3,24	3,24	3,24	3,24	3,24	3,24	3,24	3,24	3,24																																																																																																																																																																																																																																																																																																																													
	1,25	0,81	1,01	1,26	1,66	2,26	2,77	3,24	4,24	4,24	4,24	4,24	4,24	4,24	4,24	4,24	4,24																																																																																																																																																																																																																																																																																																																													
N_{Rk} [kN]	0,40	0,46	0,76	0,88	1,03	1,27	1,43	1,43	1,43	1,43	1,43	1,43	1,43	1,43	1,43	1,43	1,43																																																																																																																																																																																																																																																																																																																													
	0,50	0,46	0,76	0,88	1,03	1,27	1,60	1,80	1,80	1,80	1,80	1,80	1,80	1,80	1,80	1,80	1,80																																																																																																																																																																																																																																																																																																																													
	0,55	0,46	0,76	0,88	1,03	1,27	1,60	1,90	1,90	1,90	1,90	1,90	1,90	1,90	1,90	1,90	1,90																																																																																																																																																																																																																																																																																																																													
	0,63	0,46	0,76	0,88	1,03	1,27	1,60	1,90	2,34	2,34	2,34	2,34	2,34	2,34	2,34	2,34	2,34																																																																																																																																																																																																																																																																																																																													
	0,75	0,46	0,76	0,88	1,03	1,27	1,60	1,90	2,49	2,49	2,49	2,49	2,49	2,49	2,49	2,49	2,49																																																																																																																																																																																																																																																																																																																													
	0,88	0,46	0,76	0,88	1,03	1,27	1,60	1,90	2,49	2,49	2,49	2,49	2,49	2,49	2,49	2,49	2,49																																																																																																																																																																																																																																																																																																																													
	1,00	0,46	0,76	0,88	1,03	1,27	1,60	1,90	2,49	2,49	2,49	2,49	2,49	2,49	2,49	2,49	2,49																																																																																																																																																																																																																																																																																																																													
	1,25	0,46	0,76	0,88	1,03	1,27	1,60	1,90	2,49	2,49	2,49	2,49	2,49	2,49	2,49	2,49	2,49																																																																																																																																																																																																																																																																																																																													
M_{Rk} [Nm]																																																																																																																																																																																																																																																																																																																																														
<p>If both components I and II are made of S320GD or S350GD the grey highlighted values may be increased by 8,0%.</p>																																																																																																																																																																																																																																																																																																																																														
<p>Self piercing screw</p> <p>Hilti S-MS 41 Z 4,8 x L Hilti S-MS 41 C 4,8 x L Hilti S-MS 51 Z 4,8 x L Hilti S-MS 51 C 4,8 x L with hexagon head and sealing washer $\geq \varnothing 14$ mm</p>											<p>Annex 5</p>																																																																																																																																																																																																																																																																																																																																			

Annex 3:
ETA-10/0182, Annex 6

Material:

Fastener: carbon steel, case hardened and galvanized or coated

Washer: carbon steel, galvanized or coated
stainless Steel (1.4301) - EN 10088

Component I: aluminium alloy with $R_{m,min} = 215 \text{ N/mm}^2$ - EN 573

Component II: aluminium alloy with $R_{m,min} = 215 \text{ N/mm}^2$ - EN 573

Drilling capacity: $\Sigma t_i \leq 2,50 \text{ mm}$

Timber substructures:
no performance determined

t [mm]	t _i [mm]						
	0,50	0,60	0,70	0,80	1,00	1,20	
V _{rel,k} [kN]	0,50	0,71	0,71	0,71	0,71	0,71	0,71
	0,60	0,71	0,92	0,92	0,92	0,92	0,92
	0,70	0,71	0,92	1,14	1,14	1,14	1,14
	0,80	0,71	0,92	1,14	1,35	1,35	1,35
	1,00	0,71	0,92	1,14	1,35	1,88	1,88
	1,20	0,71	0,92	1,14	1,35	1,88	2,28
N _{s,k} [kN]	0,50	0,35	0,49	0,52	0,52	0,52	0,52
	0,60	0,35	0,49	0,63	0,63	0,63	0,63
	0,70	0,35	0,49	0,63	0,73	0,73	0,73
	0,80	0,35	0,49	0,63	0,77	0,84	0,84
	1,00	0,35	0,49	0,63	0,77	1,00	1,05
	1,20	0,35	0,49	0,63	0,77	1,00	1,26
N _{R,ilk} [kN]	0,35	0,49	0,63	0,77	1,00	1,29	
M _{torq} [Nm]							

The pull-through-capacities of the grey highlighted values N_{s,k} have been determined according to EN 1999-1-4:2007 section 8.3.3.1 by calculation. This values N_{s,k} may be increased by 6,9% when using the type „S-MS 5x“.

Self piercing screw	
Hilti S-MS 41 Z 4,8 x L Hilti S-MS 41 C 4,8 x L Hilti S-MS 51 Z 4,8 x L Hilti S-MS 51 C 4,8 x L with hexagon head and sealing washer $\geq \varnothing 14 \text{ mm}$	Annex 6

Annex 4:
ETA-10/0182, Annex 7

Material:

Fastener: carbon steel, case hardened and galvanized or coated

Washer: carbon steel, galvanized or coated stainless Steel (1.4301) - EN 10088

Component I: aluminium alloy with $R_{m,min} = 165 \text{ N/mm}^2$ - EN 573

Component II: aluminium alloy with $R_{m,min} = 165 \text{ N/mm}^2$ - EN 573

Drilling capacity: $\Sigma t_i \leq 2,50 \text{ mm}$

Timber substructures:
no performance determined

t [mm]	t _i [mm]						
	0,50	0,60	0,70	0,80	1,00	1,20	
V _{rel,k} [kN]	0,50	0,55	0,55	0,55	0,55	0,55	0,55
	0,60	0,55	0,71	0,71	0,71	0,71	0,71
	0,70	0,55	0,71	0,88	0,88	0,88	0,88
	0,80	0,55	0,71	0,88	1,04	1,04	1,04
	1,00	0,55	0,71	0,88	1,04	1,44	1,44
	1,20	0,55	0,71	0,88	1,04	1,44	1,83
N _{2,x} [kN]	0,50	0,27	0,38	0,40	0,40	0,40	0,40
	0,60	0,27	0,38	0,48	0,48	0,48	0,48
	0,70	0,27	0,38	0,48	0,56	0,56	0,56
	0,80	0,27	0,38	0,48	0,59	0,64	0,64
	1,00	0,27	0,38	0,48	0,59	0,76	0,80
	1,20	0,27	0,38	0,48	0,59	0,76	0,98
N _{2,lik} [kN]	0,27	0,38	0,48	0,59	0,76	1,03	
M _{1,100m} [Nm]							

The pull-through-capacities of the grey highlighted values N_{2,x} have been determined according to EN 1999-1-4:2007 section 8.3.3.1 by calculation. This values N_{2,x} may be increased by 6,9% when using the type „S-MS 5x“.

Self piercing screw		Annex 7
Hilti S-MS 41 Z 4,8 x L Hilti S-MS 41 C 4,8 x L Hilti S-MS 51 Z 4,8 x L Hilti S-MS 51 C 4,8 x L with hexagon head and sealing washer ≥ Ø14 mm		

Annex 5:
ETA-10/0182, Annex 8

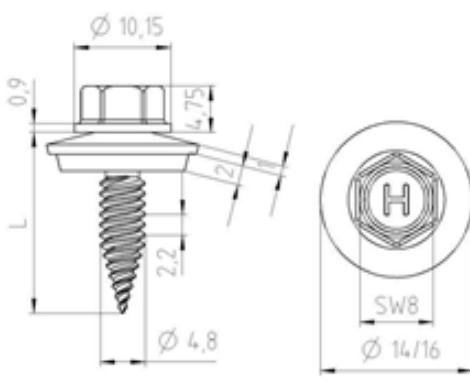

Material:

Fastener: carbon steel, case hardened and galvanized or coated

Washer: carbon steel, galvanized or coated
stainless Steel (1.4301) - EN 10088

Component I: aluminium alloy with $R_{m,min} = 215 \text{ N/mm}^2$ - EN 573

Component II: S280GD, S320GD, S350GD - EN 10346

Drilling capacity: $\Sigma t_i \leq 2,50 \text{ mm}$

Timber substructures:
no performance determined

t [mm]	t _i [mm]							
	0,50	0,55	0,63	0,75	0,88	1,00	1,25	
V _{FeK} [kN]	0,50	0,71	0,71	0,71	0,71	0,71	0,71	
	0,60	0,71	0,71	0,92	0,92	0,92	0,92	
	0,70	0,71	0,71	0,92	1,14	1,14	1,14	
	0,80	0,71	0,71	0,92	1,14	1,35	1,35	
	1,00	0,71	0,71	0,92	1,14	1,35	1,88	
	1,20	0,71	0,71	0,92	1,14	1,35	1,88	
N _{2,x} [kN]	0,50	0,52	0,52	0,52	0,52	0,52	0,52	
	0,60	0,63	0,63	0,63	0,63	0,63	0,63	
	0,70	0,73	0,73	0,73	0,73	0,73	0,73	
	0,80	0,76	0,84	0,84	0,84	0,84	0,84	
	1,00	0,76	0,87	1,04	1,05	1,05	1,05	
	1,20	0,76	0,87	1,04	1,26	1,26	1,26	
N _{2,ilk} [kN]	0,76	0,87	1,04	1,28	1,58	1,86	2,42	
M _{1,perm} [Nm]								

The pull-through-capacities of the grey highlighted values $N_{2,x}$ have been determined according to EN 1999-1-4:2007 section 8.3.3.1 by calculation. This values $N_{2,x}$ may be increased by 6,9% when using the type „S-MS 5x“.

Self piercing screw	
Hilti S-MS 41 Z 4,8 x L Hilti S-MS 41 C 4,8 x L Hilti S-MS 51 Z 4,8 x L Hilti S-MS 51 C 4,8 x L with hexagon head and sealing washer $\geq \varnothing 14 \text{ mm}$	Annex 8

Annex 6:
ETA-10/0182, Annex 9

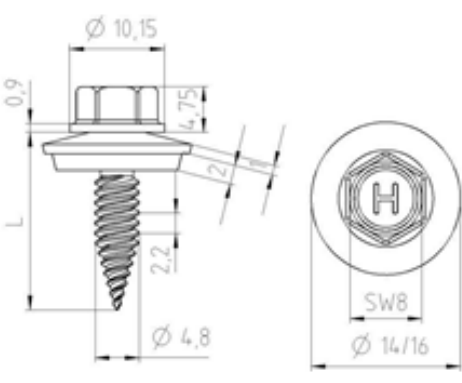

Material:

Fastener: carbon steel, case hardened and galvanized or coated

Washer: carbon steel, galvanized or coated stainless Steel (1.4301) - EN 10088

Component I: aluminium alloy with $R_{m,min} = 165 \text{ N/mm}^2$ - EN 573

Component II: S280GD, S320GD, S350GD - EN 10346

Drilling capacity: $\Sigma t_i \leq 2,50 \text{ mm}$

Timber substructures:
no performance determined

t [mm]	t _i [mm]							
	0,50	0,55	0,63	0,75	0,88	1,00	1,25	
V _{rel} [kN]	0,50	0,55	0,55	0,55	0,55	0,55	0,55	0,55
	0,60	0,55	0,55	0,71	0,71	0,71	0,71	0,71
	0,70	0,55	0,55	0,71	0,88	0,88	0,88	0,88
	0,80	0,55	0,55	0,71	0,88	1,04	1,04	1,04
	1,00	0,55	0,55	0,71	0,88	1,04	1,44	1,44
	1,20	0,55	0,55	0,71	0,88	1,04	1,44	1,83
N _{ex} [kN]	0,50	0,40	0,40	0,40	0,40	0,40	0,40	0,40
	0,60	0,48	0,48	0,48	0,48	0,48	0,48	0,48
	0,70	0,58	0,58	0,58	0,58	0,58	0,58	0,58
	0,80	0,64	0,64	0,64	0,64	0,64	0,64	0,64
	1,00	0,78	0,80	0,80	0,80	0,80	0,80	0,80
	1,20	0,78	0,87	0,96	0,96	0,96	0,96	0,96
N _{R,ilk} [kN]	0,76	0,87	1,04	1,28	1,58	1,86	2,42	
M _{torq} [Nm]								

The pull-through-capacities of the grey highlighted values $N_{R,k}$ have been determined according to EN 1999-1-4:2007 section 8.3.3.1 by calculation. This values $N_{R,k}$ may be increased by 6,9% when using the type „S-MS 5x“.

Self piercing screw		Annex 9
Hilti S-MS 41 Z 4,8 x L Hilti S-MS 41 C 4,8 x L Hilti S-MS 51 Z 4,8 x L Hilti S-MS 51 C 4,8 x L with hexagon head and sealing washer $\geq \text{Ø}14 \text{ mm}$		